

MANUAL NO.
PRT9206

ILLUSTRATED PARTS LIST

STYLES

39500 QA
39500 QB
39500 QP
39500 RA
39500 RF
39500 RR
39500 RS
39500 SE
39500 SF
39500 TE
39500 CQA
39500 CQB
39500 CRF
39500 SQB
39500 SRF
39500 CSRF

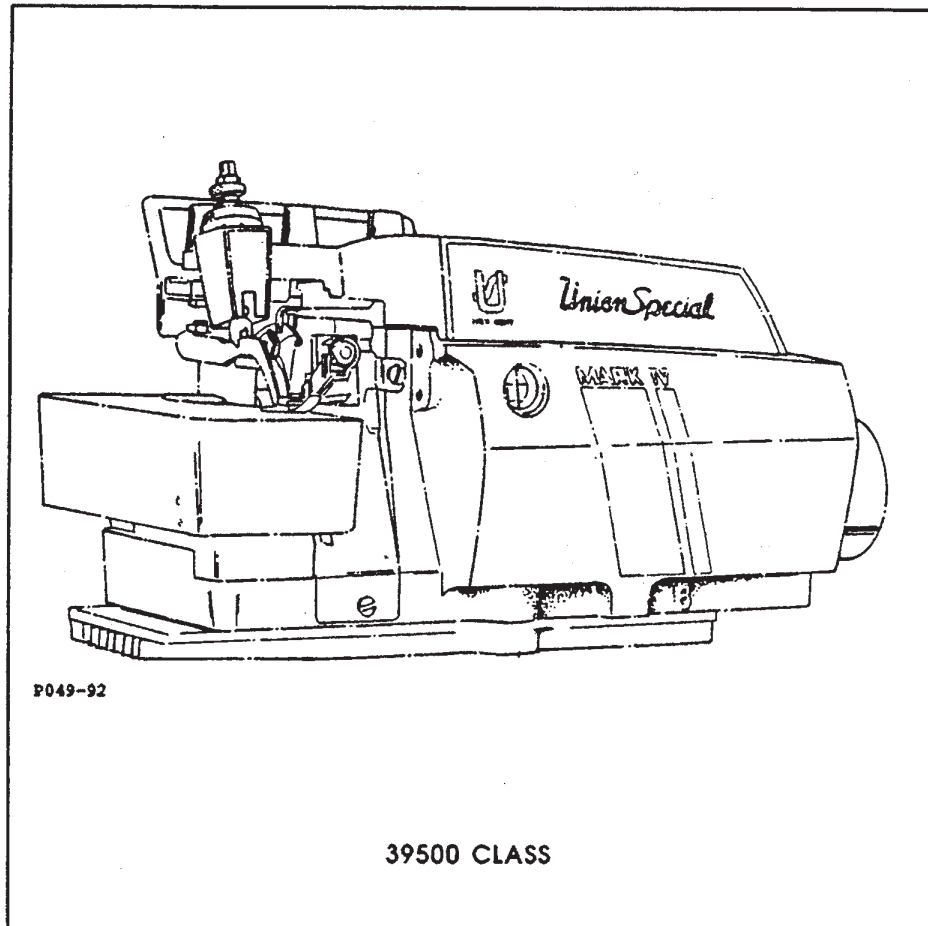

Union Special
INDUSTRIAL SEWING EQUIPMENT

Manual No. PRT9206 Illustrated Parts List for 39500 Series Machines

First Edition Copyright 1993

By

Union Special Corporation Rights Reserved In All Countries

Printed in U.S.A. October 1993

PREFACE

This parts manual has been prepared to assist you in locating individual parts or assemblies on 39500 Series machines. It can be used in conjunction with Union Special Adjusting Manual INS9207.

It is the desire of Union Special that each machine run at its optimum performance. Parts listed in this manual are designed specifically for your machine and are manufactured with utmost precision to assure long lasting service.

This manual has been comprised on the basis of available information. Changes in design and/or improvements may incorporate a slight modification of configuration in illustrations or part numbers.

On the following pages are illustrations and terminology used in describing the parts used on 39500 Series machines.

SAFETY RULES



General Operating Directions

The sewing machines described in this instruction manual are prohibited from being put into service until it has been ascertained that the sewing units, in which these sewing machines will be built-in have conformed with the EC Council Directives (89/392/EEC, Annex II B).

1. Before putting the machines described in this manual into service, carefully read the instructions. The starting of each machine is only permitted after taking notice of the instructions and by qualified operators.

IMPORTANT! Before putting the machine into service, also read the safety rules and instruction from the motor supplier.

2. Observe the national safety rules valid for your country.
3. Each machine is only allowed to be used as foreseen. The foreseen use of the particular machine is described in paragraph "STYLES OF MACHINES" of this instruction manual. Another use, going beyond the description, is not as foreseen.
4. All safety devices must be in position when the machine is ready for work or in operation. Operation of the machine without the appertaining safety devices is prohibited.
5. The following safety devices are components of the sewing machines: Finger guard, needle lever eyelet guard, needle bar guard, needle break protection shield and handwheel-belt guard.
6. When gauge parts are exchanged (i.e. needle, presser foot, needle plate, feed dog and bobbin), during threading, when the operator leaves the workplace, during service work, the machine must be isolated from the main power by switching off the main switch or disconnecting the main plug. On mechanically operated clutch motors without a start inhibitor it is necessary to wait until the motor has stopped.

7. Wear safety glasses.
8. In case of machine conversions and changes all valid safety rules must be considered. Conversions and changes are made at your own risk.
9. Commissioning of the sewing head is prohibited until such time as the entire sewing unit is found to comply with EC regulations.
10. The warning hints in the instructions are marked with one of these two symbols:



Items require special attention



Danger of injury to operative or service staff

Be sure to observe and adhere to these indications and to the generally applicable regulations.

Special Operating Directions

11. For the following the machine has to be disconnected from the power supply by turning off the main switch or by pulling out the main plug:
 - 11.1 For threading needle(s), looper, spreader etc.
 - 11.2 For replacing sewing parts such as needle, presser foot, throat plate, looper, spreader, feed dog, needle guard, folder, fabric guide etc.
 - 11.3 When leaving the workplace and when the workplace is unattended.
 - 11.4 For maintenance work.
 - 11.5 When using clutch motors without actuation lock, wait until the motor is stopped totally.

General Maintenance Directions

12. Maintenance, repair and conversion work (see item 8) must be done only by trained technicians or special skilled personnel under consideration of the instructions.
13. Any work on the electrical equipment must be done by an electrician or under direction and supervision of special skilled personnel.

Special Maintenance Directions

14. Work on parts and equipment under electrical tension is not permitted.
15. Before doing maintenance and repair work on the pneumatic equipment, the machine has to be disconnected from the compressed air supply. In case of existing residual air pressure after disconnecting from compressed air supply (e.g. pneumatic equipment with air tank), the pressure has to be removed by bleeding.

Exceptions are only allowed for adjusting work and function checks done by special skilled personnel.

Standards

17. The sewing machines described in this manual are built according to the following standards:
 - EN292-2 Safety of machinery-basic concepts, general principles for design.
 - IEC204-3-1/EN60204-3-1 Electrical equipment of industrial machines. Part 3: Particular requirements for sewing machines, units and systems.

CONTENTS

•ORDERING REPAIR PARTS	4
•NEEDLES	5
•TERMS	6
•TORQUE REQUIREMENTS	6
•EXPLODED VIEWS AND DESCRIPTION OF PARTS	
•MAIN FRAME, MISCELLANEOUS COVERS & PRESSER FOOT RELEASE PARTS	9
•MAIN FRAME & MISCELLANEOUS COVERS	11
•CRANKSHAFT MECHANISM & BUSHINGS	13
•FEED MECHANISM	15
•NEEDLE DRIVING PARTS	17
•UPPER & LOWER LOOPER DRIVING PARTS	19
•UPPER & LOWER KNIFE PARTS	21
•FOOT LIFTER, CHAIN CUTTING KNIFE & MISCELLANEOUS EYELETS	23
•THREAD TENSION PARTS	25
•FEED DOGS, THROAT PLATE & PRESSER FEET	27
•FEED DOGS, THROAT PLATE & PRESSER FEET	29
•FEED DOGS, THROAT PLATE & PRESSER FEET	31
•POWER AIR-KLIPP® CHAIN CUTTER	33
•FULLY-SUBMERGED TABLING	34
•SEMI-SUBMERGED TABLING	35
•PNEUMATIC CONTROL	37
•THREAD STAND & MISCELLANEOUS ACCESSORIES	39
•NUMERICAL INDEX OF PARTS	41
•NOTES	42

ORDERING REPAIR PARTS

ILLUSTRATIONS

This manual has been arranged to simplify ordering repair parts. Exploded views of various sections of the mechanism are shown so that the parts may be seen in their actual position in the machine. On the page opposite the illustration will be found a listing of the parts with their part numbers, description and the number of pieces required in the particular view being shown.

Numbers in the first column are reference numbers only, and merely indicate the position of the part in the illustration. The reference number should never be used in ordering parts. Always use the part number listed in the second column.

Component parts of sub-assemblies which can be furnished for repairs are indicated by indenting their descriptions under the description of the main sub-assembly. As an example refer to the text below.

9.	29126 EC	Upper Looper Drive Shaft Assembly	1
10.	22503 F	Screw	1
11.	39543 E	Cam Follower Locking Clamp	1

It will be noted in the above example that the cam follower, bushing and cam guide and the upper looper drive shaft are not listed. The reason is that replacement of these parts individually is not recommended, so the complete upper looper drive shaft assembly should be ordered.

When a part is common to all machines covered in this manual, no specific usage will be mentioned in the description. However, when the parts for the various machines are not the same, the specific usage will be mentioned in the description and, if necessary, the difference will be shown in the illustration.

A numerical index of all the parts shown in this manual is located at the back. This will facilitate locating the illustration and description when only a part number is known.

IDENTIFYING PARTS

Where the construction permits, each part is stamped with its part number. On some of the smaller parts and on those where construction does not permit, an identification letter is stamped in to distinguish the part from similar ones.

PLEASE NOTE: Part numbers represent the same part, regardless of which manual they appear. On all orders please include part number, name and style of machine for which the part was ordered.

NEEDLES

Each needle has both a type and size number. The type number denotes the kind of shank, point, length, groove, finish and other details. The size number, stamped on the needle shank, denotes the largest diameter of the blade measured between the shank and the eye. Collectively, the type number and size number represent the complete symbol which is given on the label of all needles packed and sold by Union Special.

<u>TYPE</u>	<u>DESCRIPTION</u>
154 GAS	Round shank, round point, curved blade, standard length, single groove, struck groove, spotted, chromium plated. Sizes available 055/022, 065/025, 070/027, 075/029, 080/032, 090/036, 100/040, 110/044, 125/049, 140/054, 150/060.
154 GBS	Round shank, round point, curved blade, standard length, double groove, struck groove, spotted, chromium plated. Sizes available 070/027, 075/029, 080/032.
154 GHS	Round shank, ball point, curved blade, standard length, single groove, struck groove, spotted, chromium plated. Sizes available 065/025, 070/027, 075/029, 080/032, 090/036.
162 SAS	Round shank, round point, curved blade, short length, double groove, struck groove, spotted, chromium plated. Sizes available 055/022, 065/025, 070/027, 075/029, 080/032, 090/036, 100/040, 110/044.

APPLICATION

Machine Style	Needle Type	Needle Size
39500 QA, QB, RF, TE, CQA, CQB, CRF	154 GAS	070/027
39500 SE	154 GAS	080/032
39500 QP	154 GAS	090/036
39500 RA, SF	154 GAS	100/040
39500 RS	154 GBS	075/029
39500 RR	154 GHS	080/032
39500 SRF, CSR	162 SAS	065/025
39500 SQB	162 SAS	070/027

When changing the needle, make sure it is fully inserted in the needle driving arm before the nut is tightened.

To have needles promptly and accurately filled, an empty package, a needle sample, or the type and size number should be forwarded. Use the description on the label. A complete order should read as follows: "100 needles, type 154 GAS, size 070/027".

TERMS

Prices are net cash and subject to change without notice. All shipments are forwarded F.O.B. shipping point. A charge is made to cover postage and insurance.

TORQUE REQUIREMENTS

Torque measured in inch-pounds or centimeter/kilograms is a rotating force in pounds applied through a distance by a lever in inches, feet or meters. This is accomplished by a wrench, screwdriver, etc. Many of these devices are available, which when set at the proper amount of torque will tighten the part to the correct amount and no tighter.

All straps and eccentrics should be tightened to 26-28 inch-pounds (2.9-3.2Nm) unless otherwise noted. All other nuts, bolts, screws, etc. should be tightened by hand as tightly as possible, unless otherwise noted.

Screws requiring a specific torque will be indicated on the illustrations in 39500 Parts Manual PRT9206.

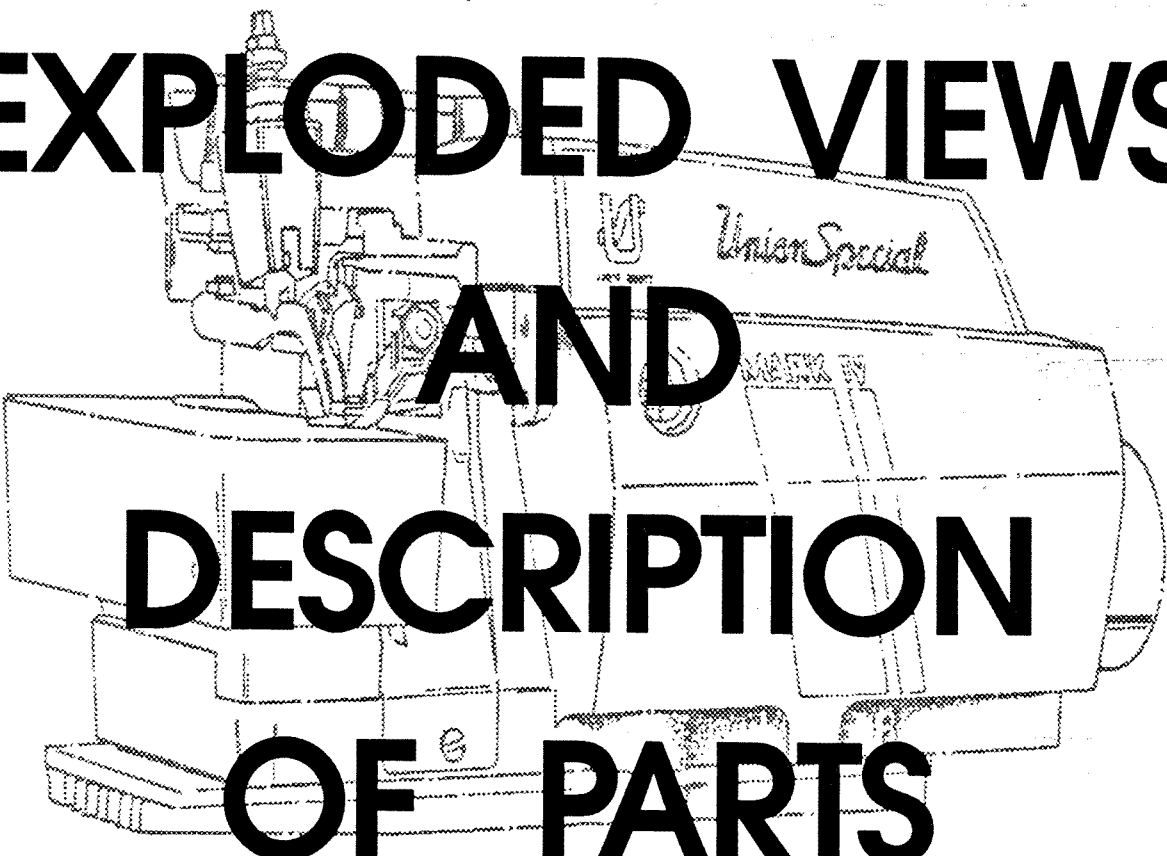

**EXPLODED VIEWS
AND
DESCRIPTION
OF PARTS**

The background image is a technical exploded view diagram of a Union Special typewriter. The diagram shows the main body of the typewriter, the carriage assembly, and the keyboard assembly. The text "Union Special" is written in a cursive font on the side of the typewriter body. The title "EXPLODED VIEWS AND DESCRIPTION OF PARTS" is overlaid in large, bold, black, sans-serif capital letters across the center of the diagram.

8049-92

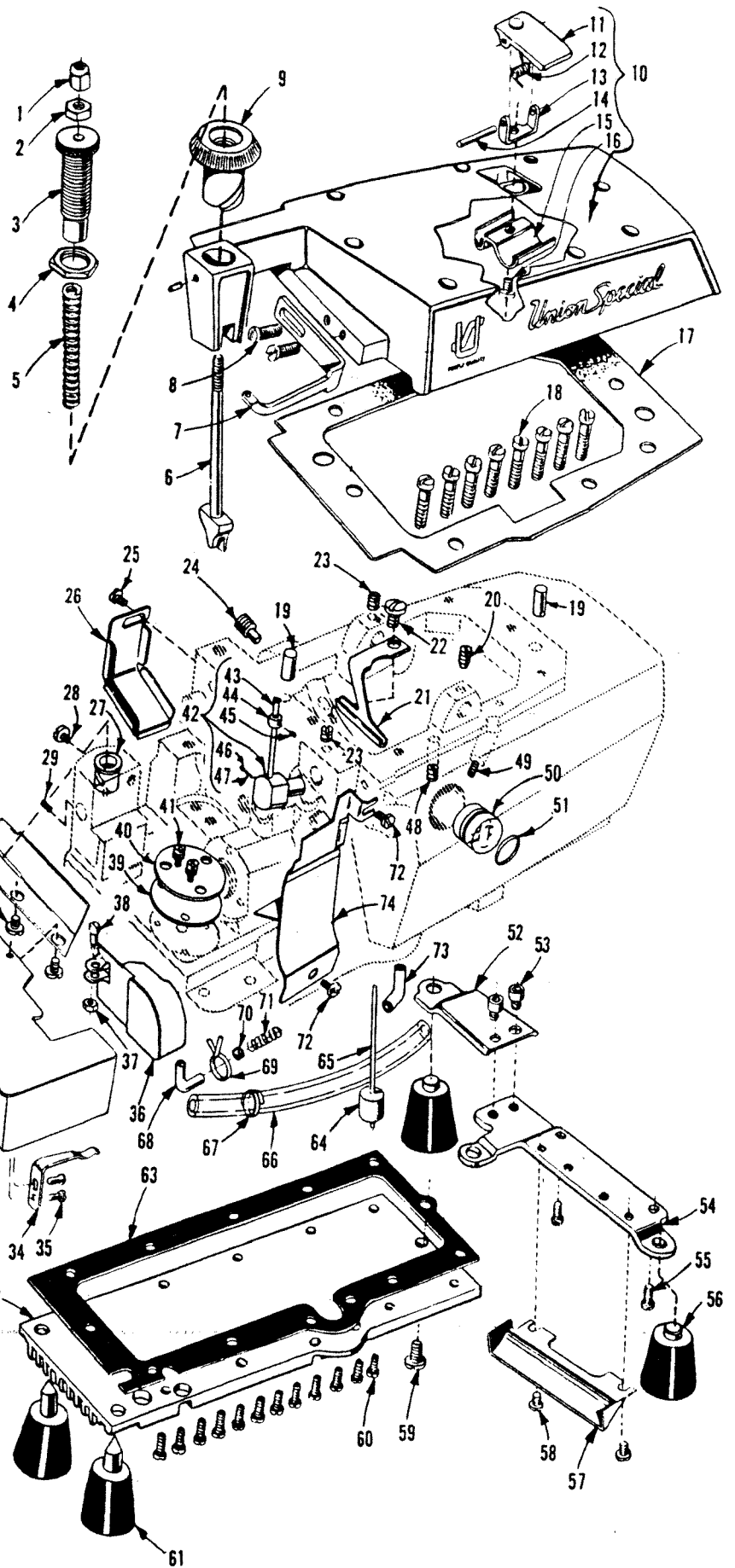
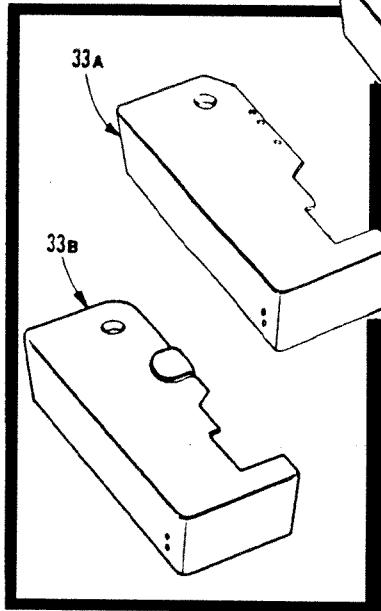
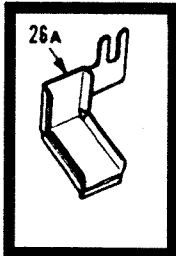
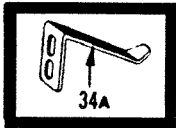
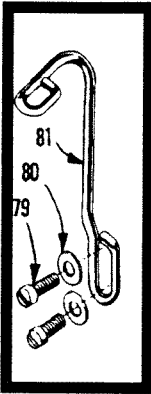
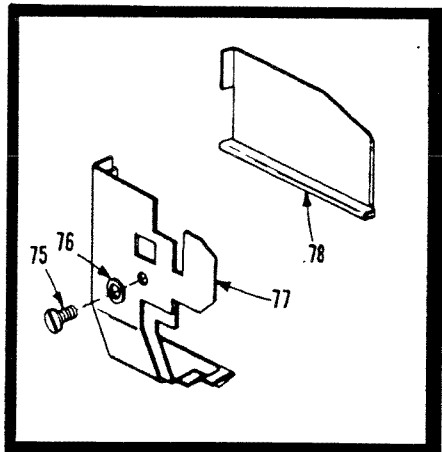

MAIN FRAME, MISCELLANEOUS COVERS & PRESSER FOOT RELEASE PARTS

Ref. No.	Part No.	Description	Amt. Req.
1.	39557B	Presser Spring Plunger Cap Nut	1
2.	39557E	Presser Spring Plunger Locking Nut	1
3.	39557C	Presser Spring Plunger Adjusting Screw	1
4.	39557F	Lock Nut	1
5.	39557	Presser Spring	1
6.	39557A	Presser Spring Plunger	1
7.	39563F	Top Cover Needle Thread Eyelet, for all Styles except 39500 RA, SF	1
-	39563T	Top Cover Needle Thread Eyelet, for Styles 39500 RA, SF	1
8.	22569B	Screw, for top cover needle thread eyelet	2
9.	39556A	Presser Foot Release Bushing	1
10.	39582AD	Top Cover	1
11.	39582AF	Oil Filler Cover	1
12.	39582V	Spring	1
13.	39582AG	Hinge Bracket	1
14.	51-103BLK	Hinge Pin	1
15.	39582W	Oil Guard	1
16.	22562A	Screw, for hinge bracket	1
17.	39582BZ	Top Cover Gasket	1
18.	22541	Screw, for top cover	8
19.	667D-8	Dowel Pin	2
20.	22565S	Spot Screw, for upper looper drive lever shaft	1
21.	39594R	Oil Collector Plate	1
22.	22569D	Screw, for oil collector plate	1
23.	22565	Set Screw, for upper looper thread tube assembly & upper looper drive lever shaft	1
24.	22571E	Magnetic Oil Drain Plug Screw	1
25.	90	Screw, for feed bar oil shield	1
26.	39534R	Feed Bar Oil Shield, for all Styles except 39500 CQA, CQB, CRF, CSRF	1
26A.	39534RB	Feed Bar Oil Shield, for Styles 39500 CQA, CQB, CRF, CSRF	1
27.	39501K	Cloth Plate Stud, for all Styles	1
28.	22569	Screw, for cloth plate stud	1
29.	22565F	Screw, for feed adjusting pin	1
30.	39578F	Cloth Plate Fabric Guard, for Styles 39500 QA, QB, QP, RF, RS, SE, TE, SQB, SRF	1
31.	138	Screw, for cloth plate fabric guard	2
32.	22657D-10	Screw, for cloth plate	1
33.	39501D	Cloth Plate, for all Styles except 39500 SF, CQA, CQB, CRF, CSRF	1
33A.	39501DB	Cloth Plate, for Style 39500 SF	1
-	39501E	Cloth Plate, for Style 39500 RR	1
33B.	G39501D	Cloth Plate, for Styles 39500 CQA, CQB, CRF, CSRF	1
34.	39532A	Cloth Plate Latch Spring, for all Styles except 39500 SF	1
34A.	39532E	Cloth Plate Latch Spring, for Style 39500 SF	1
35.	90	Screw, for cloth plate latch spring	2
36. thru 81. See following page			

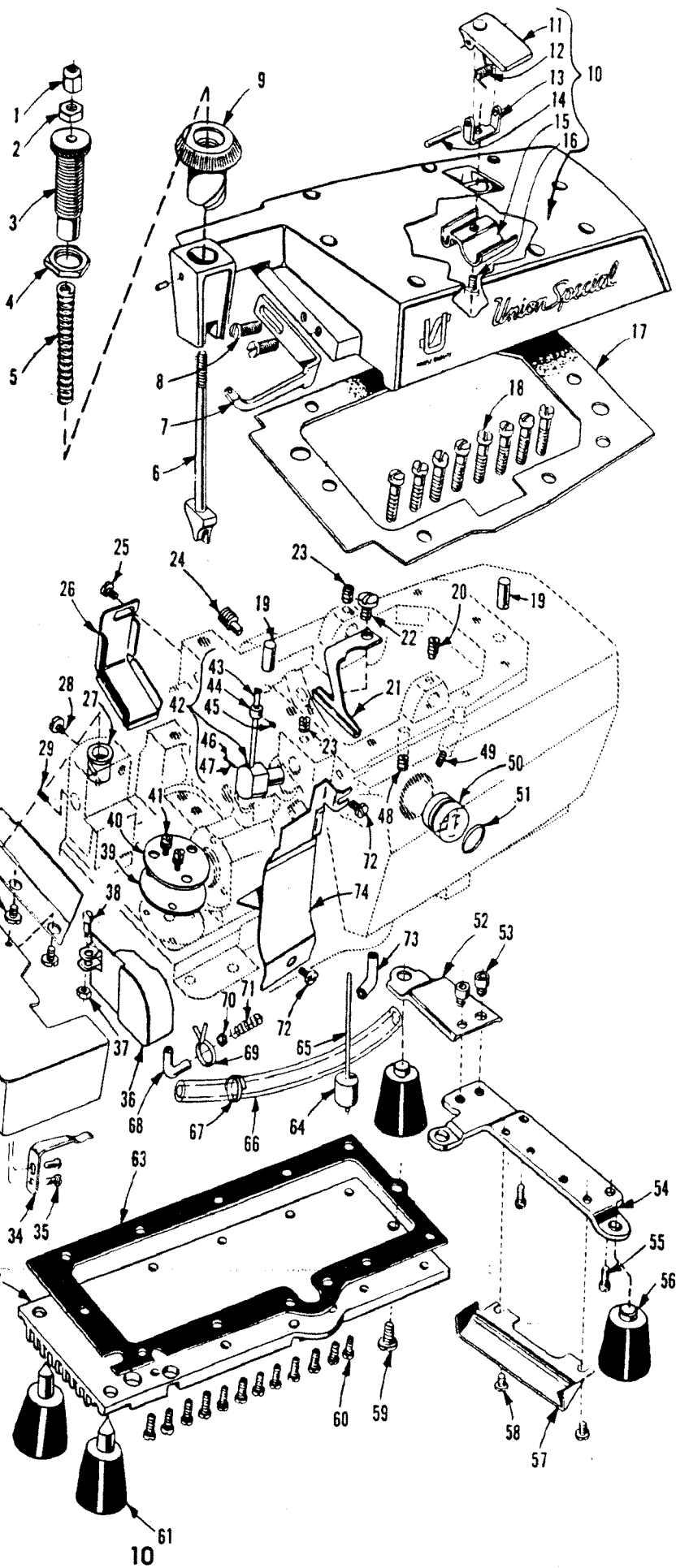
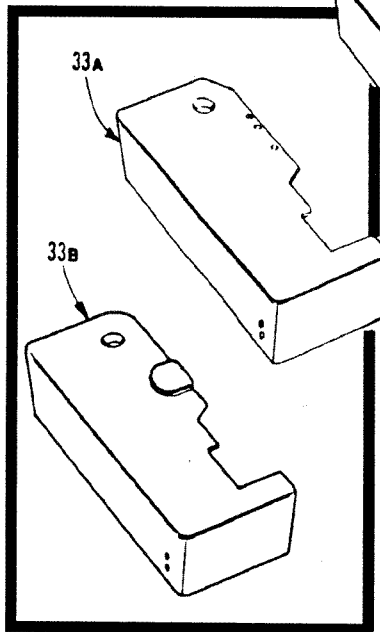
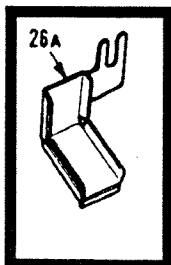
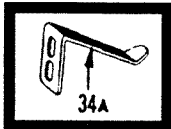
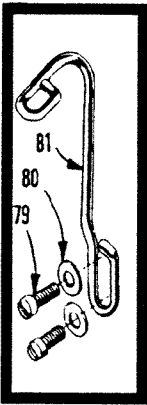
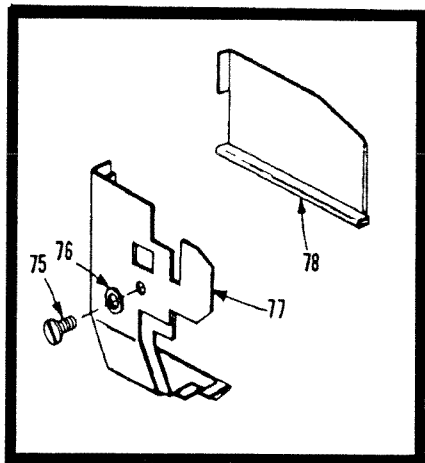

MAIN FRAME & MISCELLANEOUS COVERS

Ref. No.	Part No.	Description	Amt. Req.
1. thru 35. See preceding page			
36.	39582FE	Feed Mechanism Cover, for Styles 39500 RA, RR, SF	1
-	39582FH	Feed Mechanism Cover, for Styles 39500 CQA, CQB, CRF	1
37.	41071G	Nut, for feed mechanism cover	1
38.	86X	Screw, for feed mechanism cover	1
39.	39594H	Felt Oil Strainer	1
40.	39594G	Oil Filter Screen	1
41.	22760H	Screw, for oil filter screen and strainer	2
42.	29477MX	Upper Looper Thread Tube Assembly	1
43.	39568AN	Thread Tube	1
44.	39568AP	Collar	1
45.	1096	Screw	1
46.	22743	Set Screw	1
47.	39568J	Thread Tube Tension Spring	1
48.	22569K	Screw, for oil sight gauge	1
49.	22894AE	Screw, for lower looper driving lever shaft	1
50.	39593H	Oil Sight Gauge	1
51.	660-243	Oil Gauge Seal Ring	1
52.	39582F	Bottom Cover Extension	1
53.	22653D-4	Screw, for bottom cover extension	2
54.	39582BM	Base Plate	1
55.	22541B	Screw, for base plate	2
56.	39595	Isolator	2
57.	39582BL	Air Duct, outer	1
58.	22569D	Screw, for outer air duct	2
59.	22586T	Screw, for bottom cover	1
60.	22541B	Screw, for bottom cover	12
61.	51295B	Isolator	2
62.	39582BW	Bottom Cover	1
63.	39582BH	Gasket, for bottom cover	1
64.	39593C	Oil Gauge Float	1
65.	39593D	Oil Gauge Indicator	1
66.	666-280	Oil Tube	1
67.	RI-37	Wire Ring	1
68.	643-480BLK	Oil Tube	1
69.	660-885	Clamp	1
70.	56393G	Filter	1
71.	56393V	Spring	1
72.	22569D	Screw, for chip guard	2
73.	39593J	Elbow Fitting	1
74.	G39578T	Chip Guard, for all Styles except 39500 QB 5/32, RA, RR, RF 5/32, CRF 5/32, SQB 5/32, SRF 5/32, CSRF 5/32	1
-	G39578TB	Chip Guard, for Style 39500 RA	1
-	39578AH	Chip Guard, for Styles 39500 QB 5/32, RF 5/32, CRF 5/32, SQB 5/32, SRF 5/32, CSRF 5/32	1
-	G39578U	Chip Guard, for Style 39500 RR	1
75.	22804	Screw, for lint shield	1
76.	41358	Washer, for lint shield	1
77.	39582GJ	Lint Shield, for all Styles except 39500 RA, RR, SF	1
78.	39582GL	Side Cover, for all Styles except 39500 RA, RR, SF	1
79.	22569	Screw, for tape guide	2
80.	69H	Washer, for tape guide	2
81.	39599	Tape Guide, for Styles 39500 RA, SF 1/8	1

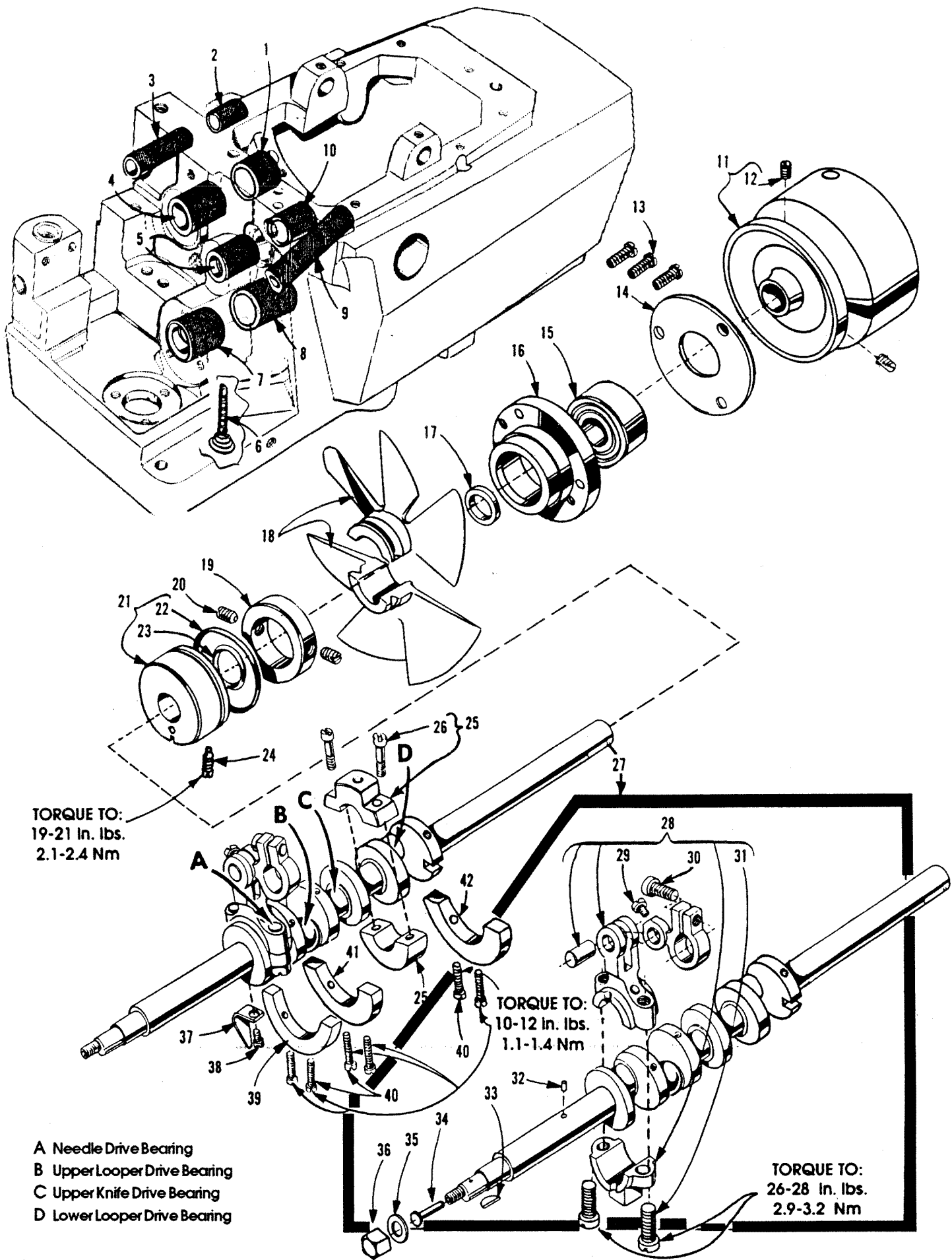

CRANKSHAFT MECHANISM & BUSHINGS

Ref. No.	Part No.	Description	Amt. Req.
1.	39573AA	Upper Knife Driving Arm Bushing, right	1
2.	39555R	Foot Lifter Shaft Bushing, right	1
3.	39555P	Foot Lifter Shaft Bushing, left	1
4.	39573K	Upper Knife Driving Arm Bushing, left	1
5.	39552U	Needle Driving Arm Crank Bushing, left	1
6.	666-94	Oil Wick and Spring	1
7.	39590AB	Crankshaft Bushing, left	1
8.	39590T	Crankshaft Bushing, inner left	1
9.	39544Z	Lower Looper Bar Bushing	1
10.	39552P	Needle Driving Arm Crank Bushing, right	1
11.	39521J	Pulley	1
12.	22650CD-4	Screw	2
13.	22569B	Screw, for crankshaft ball bearing retaining plate	3
14.	39590H	Crankshaft Ball Bearing Retaining Plate	1
15.	660-835	Crankshaft Ball Bearing	1
16.	39590G	Crankshaft Ball Bearing Housing	1
17.	39590J	Thrust Washer	1
18.	39591L	Crank Chamber Cooling Fan	1
19.	39591H	Crank Chamber Cooling Fan Collar	1
20.	22894D	Screw	2
21.	39590Y	Crankshaft Bearing, inner right.....	1
22.	660-443	Rubber "O" Ring	1
23.	660-764	Oil Seal	1
24.	22565F	Screw, for crankshaft bearing, inner right	1
25.	39590AC	Crankshaft Split Bearing	1
26.	97A	Screw	2
27.	29477JM	Crankshaft and Needle Driving Arm Crank Assembly, for Styles 39500 QA, QB, RS, SE, TE, CQA, CQB, SQB	1
	29477KE	Crankshaft and Needle Driving Arm Crank Assembly, for Styles 39500 QP, RA, RF, RR, SF, CRF, SRF, CSRF	1
28.	29477MC	Needle Driving Arm Crank and Connecting Rod Assembly	1
29.	22768C	Screw, for needle driving arm connecting rod pin	1
30.	22596H	Screw, for needle driving arm crank	2
31.	22729AB	Screw, for needle driving arm connecting rod	1
32.	51-228BLK	Vent Plug	1
33.	39541A	Feed Drive Eccentric Key	1
34.	-----	Metering Pin (refer to Chart A).....	1
35.	40-46	Washer, for crankshaft	1
36.	39536FN	Nut, for crankshaft	1
37.	39594N	Oil Splasher	1
38.	22513C	Screw, for oil splasher	1
39.	39591K	Crankshaft Counterweight, left	1
40.	22747B	Screw, for crankshaft counterweights.....	6
41.	39591A	Crankshaft Counterweight, middle	1
42.	39591B	Crankshaft Counterweight, right	1

		Pin Diameter	
Part Number	Color	Inches	Millimeters
39593U123	Violet	.123	3.125
39593U1235	Brown	.1235	3.138
39593U124	Orange	.124	3.150
39593U1245	White	.1245	3.163
39593U125	Green	.125	3.175
39593U1255	Lilac	.1255	3.187
39593U126	Yellow	.1260	3.200
39593U1265	Blue	.1265	3.213
39593U127	Black	.1270	3.225
39593U1275	Pink	.1275	3.238
39593U128	Light Blue	.1280	3.251
39593U1285	Dark Yellow	.1285	3.263
39593U129	Red	.1290	3.276

Chart A

* Metering pins have been selected according to oil flow requirements. Each machine has been fitted with a pin that will provide approximately 10 to 15 milligrams of oil per minute for speeds from 7500 to 8000 RPM.

Recommended clearance between the metering pin and the crankshaft is .0005" to .001" for speeds above 7500 RPM. For speeds below 7500 RPM a .001" to .002" clearance is recommended.

Oil flow is determined by the sewing speed and machine usage. It may become desirable to either increase or decrease the amount of oil flow by changing the size of the metering pin. In most cases selecting a pin one size larger or one size smaller will provide the correct oil flow. Refer to Chart 'A'.

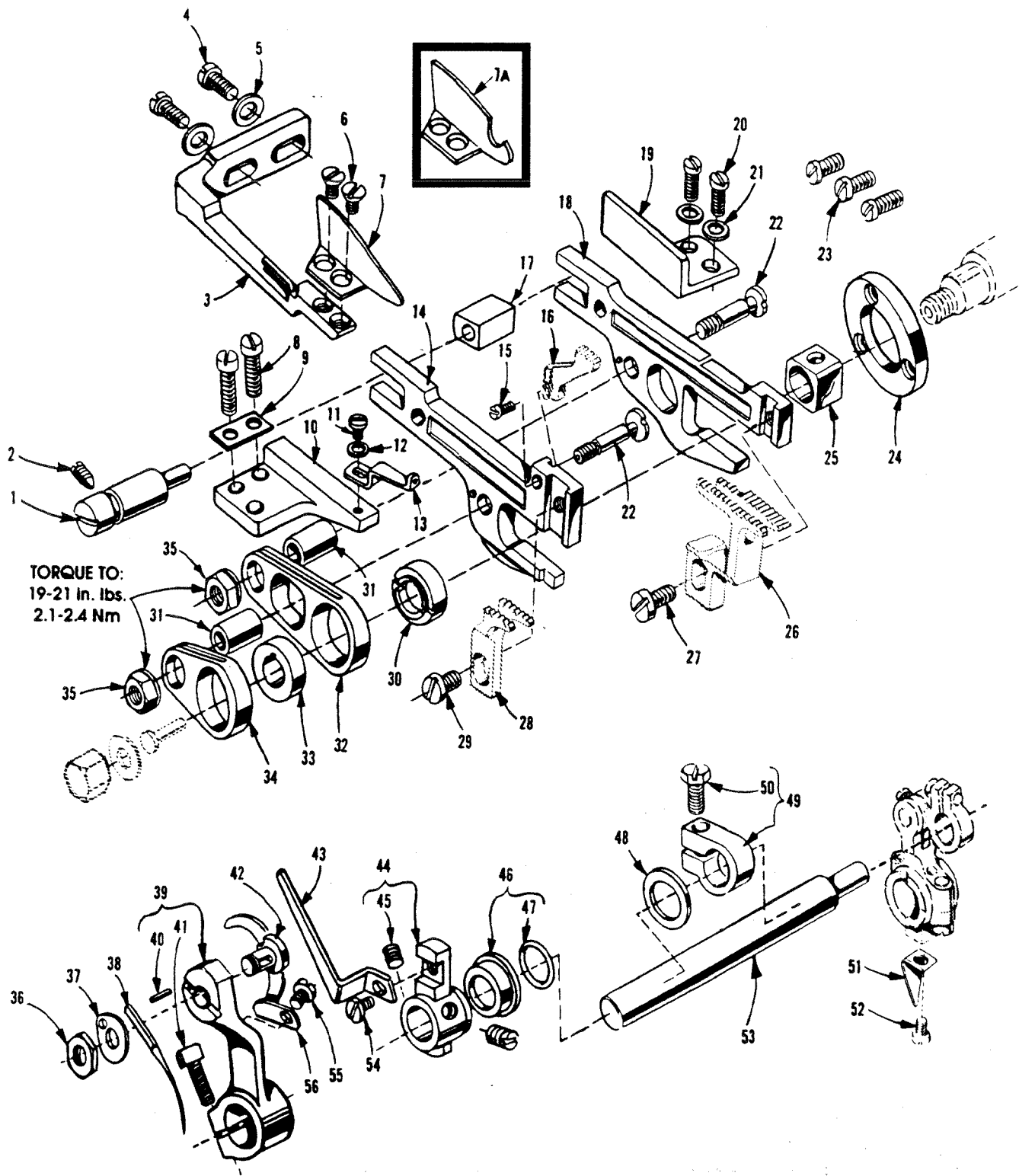

P052-92

FEED MECHANISM

Ref. No.	Part No.	Description	Amt. Req.
1.	39535C	Feed Adjusting Pin	1
2.	22565F	Screw, for feed adjusting pin	1
3.	39578P	Fabric Guard Mounting Bracket, for all Styles except 39500 CQA, CQB, CRF CSRF	1
4.	22569B	Screw, for fabric guard mounting bracket	2
5.	8372A	Washer, for mounting bracket screw	2
6.	87	Screw, for 39578R fabric guard	2
-	87B	Screw, for G39578M fabric guard	2
7.	39578R	Fabric Guard, for Styles 39500 QA, QB, QP, RA, RF, RR, RS, SE, SF	1
7A.	G39578M	Fabric Guard, for Styles TE, SQB, SRF	1
8.	22541B	Screw, for main feed bar guide, left	2
9.	39835G	Plate Washer, for 22541B	1
10.	39535W	Main Feed Bar Guide, left	1
11.	87U	Screw, for lower looper eyelet	1
12.	41358	Washer, for lower looper eyelet	1
13.	39568E	Eyelet, lower looper, for Styles 39500 CQA, CQB, CRF, CSRF	1
14.	39534	Main Feed Bar, for all Styles except 39500 SF	1
-	39534C	Main Feed Bar, for Style 39500 SF	1
15.	22797A	Screw, for chaining feed dog	1
16.	-----	Chaining Feed Dog, see pages 27, 29, 31	1
17.	39535J	Feed Bar Guide Block	1
18.	39534G	Differential Feed Bar	1
19.	39535D	Differential Feed Bar Guide, right	1
20.	22541B	Screw, for differential feed bar guide, right	2
21.	8372A	Washer, for 22569B	2
22.	39536B	Feed Bar Driving Stud	2
23.	22569G	Screw, for thrust washer	3
24.	39534AF	Differential Feed Bar Thrust Washer	1
25.	39538	Feed Lift Block	1
26.	-----	Differential Feed Dog, see pages 27, 29, 31	1
27.	93A	Screw, for main feed dog	1
28.	-----	Main Feed Dog, see pages 27, 29, 31	1
29.	22528	Screw, for differential feed dog	1
30.	-----	Differential Feed Driving Eccentric (refer to Chart B)	1
31.	39536C	Feed Bar Driving Stud Bushing	2
32.	39536AE	Differential Feed Bar Driving Connection	1
33.	-----	Main Feed Driving Eccentric (refer to Chart B)	1
34.	39536AF	Main Feed Bar Driving Connection	1
35.	39536E	Nut, for feed bar driving stud	2

36. thru 56. See following page

Machine Style	Reference Number 30 Differential Feed Driving Eccentric	Reference Number 33 Main Feed Driving Eccentric
39500 QA, CQA	39540 B-12	39540 B-10
39500 QB, QP, RF, TE, CQB, CRF, SQB, SRF, CSRF	39540 B-10	39540 B-12
39500 RA	39540 B-6	39540 B-10
39500 RR	39540 B-18	39540 B-20
39500 RS	39540 B-14	39540 B-14
39500 SE	39540 B-12	39540 B-9
39500 SF	39540 B-4	39540 B-10

Chart B

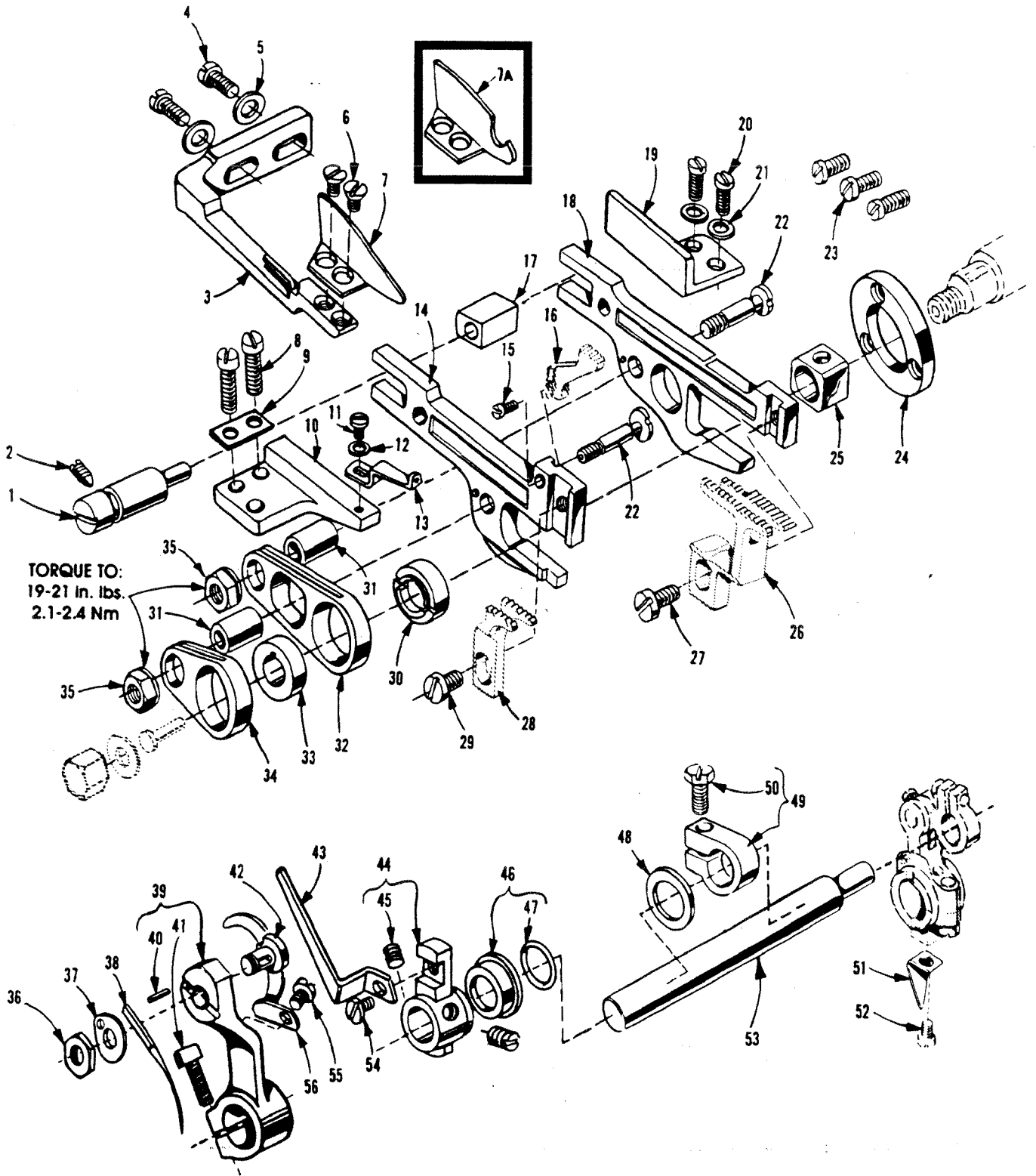

NEEDLE DRIVING PARTS

Ref. No.	Part No.	Description	Amt. Req.
1. thru 35. See preceding page			
36.	14077A	Nut, for needle clamp stud	1
37.	39551H	Needle Clamp Washer	1
38.	-----	Needle, see page 7 for the needle used on each specific Style	1
39.	39552Z	Needle Driving Arm, marked "K" for all Styles except 39500 SQB, SRF, CSRF	1
	- 39552AJ	Needle Driving Arm, marked "S", for Styles 39500 SQB, SRF, CSRF	1
40.	39552AD	Stop Pin	1
41.	22596H	Screw	1
42.	39551J	Needle Clamp Stud	1
43.	39568AM	Looper Thread Pull-off	1
44.	39568AC	Looper Thread Pull-off Lever	1
45.	88B	Screw	2
46.	39552AG	Oil Seal, for needle driving shaft	1
47.	660-207	Oil Seal Ring	1
48.	C50043H-029	Washer	1
49.	39543Y	Needle Drive Shaft Thrust Collar	1
50.	22782A	Screw	1
51.	39594N	Oil Splasher	1
52.	22513C	Screw, for oil splasher	1
53.	39552R	Needle Driving Shaft	1
54.	22513D	Screw, for looper thread pull-off	1
55.	87C	Screw, for needle thread cam pull-off	1
56.	39563G	Needle Thread Cam Pull-off	1

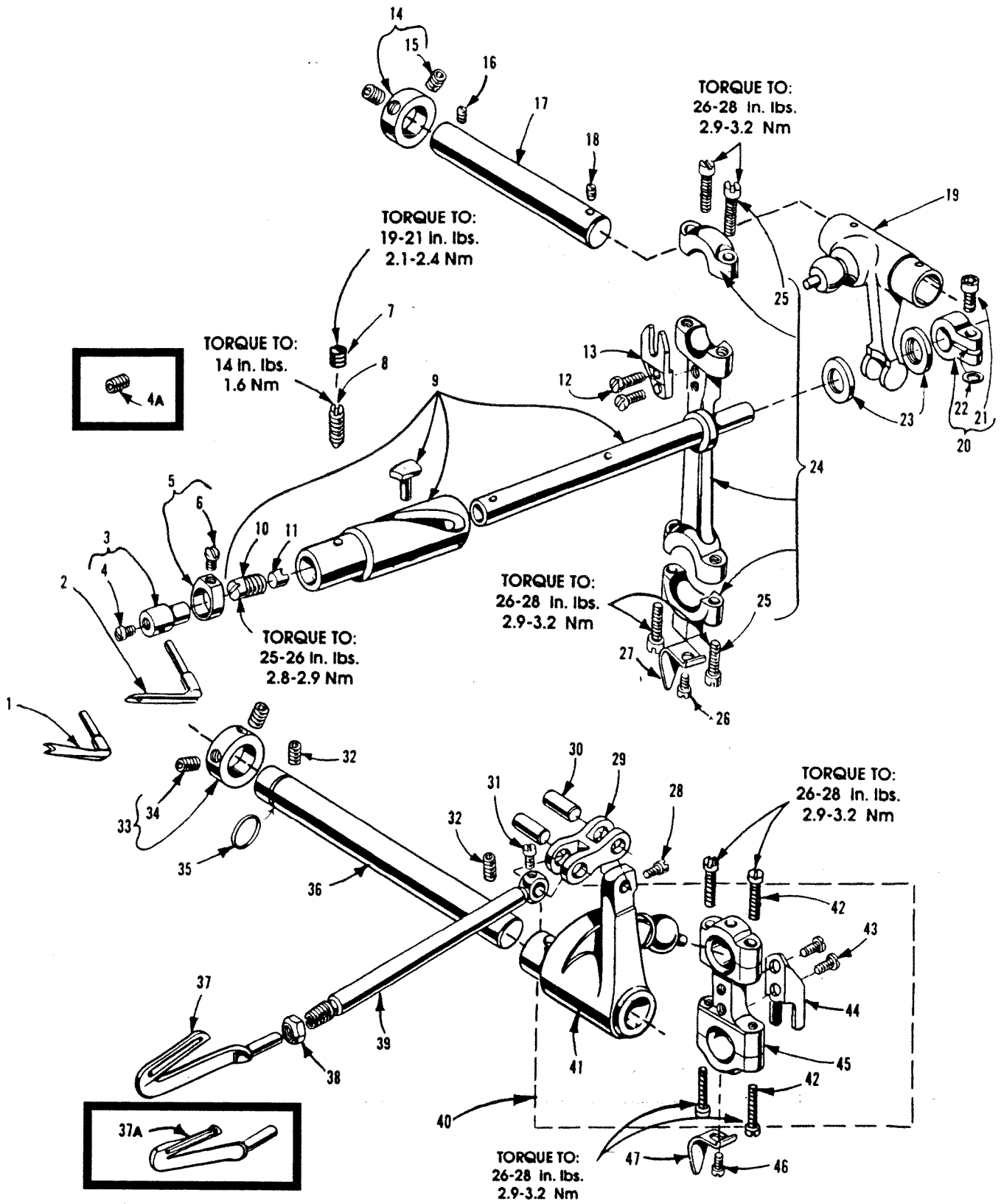

UPPER & LOWER LOOPER DRIVING PARTS

Ref. No.	Part No.	Description	Amt. Req.
1.	39560A	Upper Spreader, for Style 39500 RR (503 stitch)	1
2.	39508A	Upper Looper, for all Styles except 39500 RA, SF, TE	1
-	39508E	Upper Looper, for Styles 39500 RA, SF	1
-	G39508A	Upper Looper, for Style 39500 TE	1
3.	39543	Upper Looper Holder	1
4.	22564G	Screw	1
4A.	22894Y	Set Screw, for looper and spreader on Style 39500 RR	1
5.	39543A	Upper Looper Holder Collar	1
6.	77	Screw	1
7.	102L	Lock Screw, for 22565H	1
8.	22565H	Spot Screw, for bushing and cam guide	1
9.	29126EC	Upper Looper Drive Shaft Assembly	1
10.	22503F	Screw	1
11.	39543E	Cam Follower Locking Clamp	1
12.	97	Screw, for ball joint guide fork	2
13.	39544J	Ball Joint Guide Fork, for upper looper drive lever	1
14.	482C	Upper Looper Shaft Collar	1
15.	22894C	Set Screw	2
16.	22565	Set Screw, for upper looper rocker shaft	1
17.	39543X	Upper Looper Drive Lever Shaft	1
18.	22565S	Spot Screw, for upper looper drive lever shaft	1
19.	39543W	Upper Looper Drive Lever	1
20.	39543AT	Clamp Collar, for upper looper drive shaft	1
21.	22875M	Screw (metric)	1
22.	39543AU	Washer, for clamp collar	1
23.	39543P	Upper Looper Drive Shaft Thrust Washer	2
24.	39543AV	Upper Looper Drive Lever Connecting Rod	1
25.	22729AB	Screw	4
26.	22513C	Screw, for oil splasher	1
27.	39543N	Oil Splasher	1
28.	77	Screw, for lower looper bar connecting link pin	1
29.	39544B	Lower Looper Bar Connecting Link	1
30.	39544D	Lower Looper Bar Connecting Link Pin	2
31.	77	Screw, for lower looper bar connecting link pin	1
32.	22894AE	Set Screw, for lower looper driving shaft	2
33.	482C	Lower Looper Driving Shaft Collar	1
34.	22894C	Set Screw	2
35.	660-206	Rubber "O" Ring, for lower looper driving shaft	1
36.	39544V	Lower Looper Driving Shaft	1
37.	39508B	Lower Looper, all Styles except 39500 RA, SF	1
37A.	39508D	Lower Looper, for Styles 39500 RA, SF	1
38.	39151	Nut, for lower looper bar	1
39.	39544	Lower Looper Bar	1
40.	29126DF	Lower Looper Bar Driving Lever & Connecting Rod Assembly	1
41.	39544U	Lower Looper Bar Driving Lever	1
42.	22729AB	Screw	4
43.	97	Screw	2
44.	39544S	Ball Joint Guide Fork	1
45.	39544AA	Lower Looper Drive Lever Connecting Rod	1
46.	22513C	Screw, for oil splasher	1
47.	39594N	Oil Splasher	1

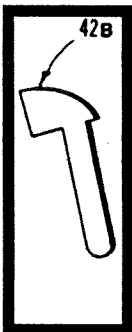
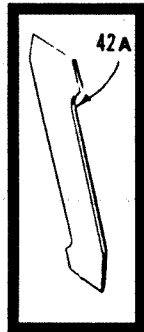
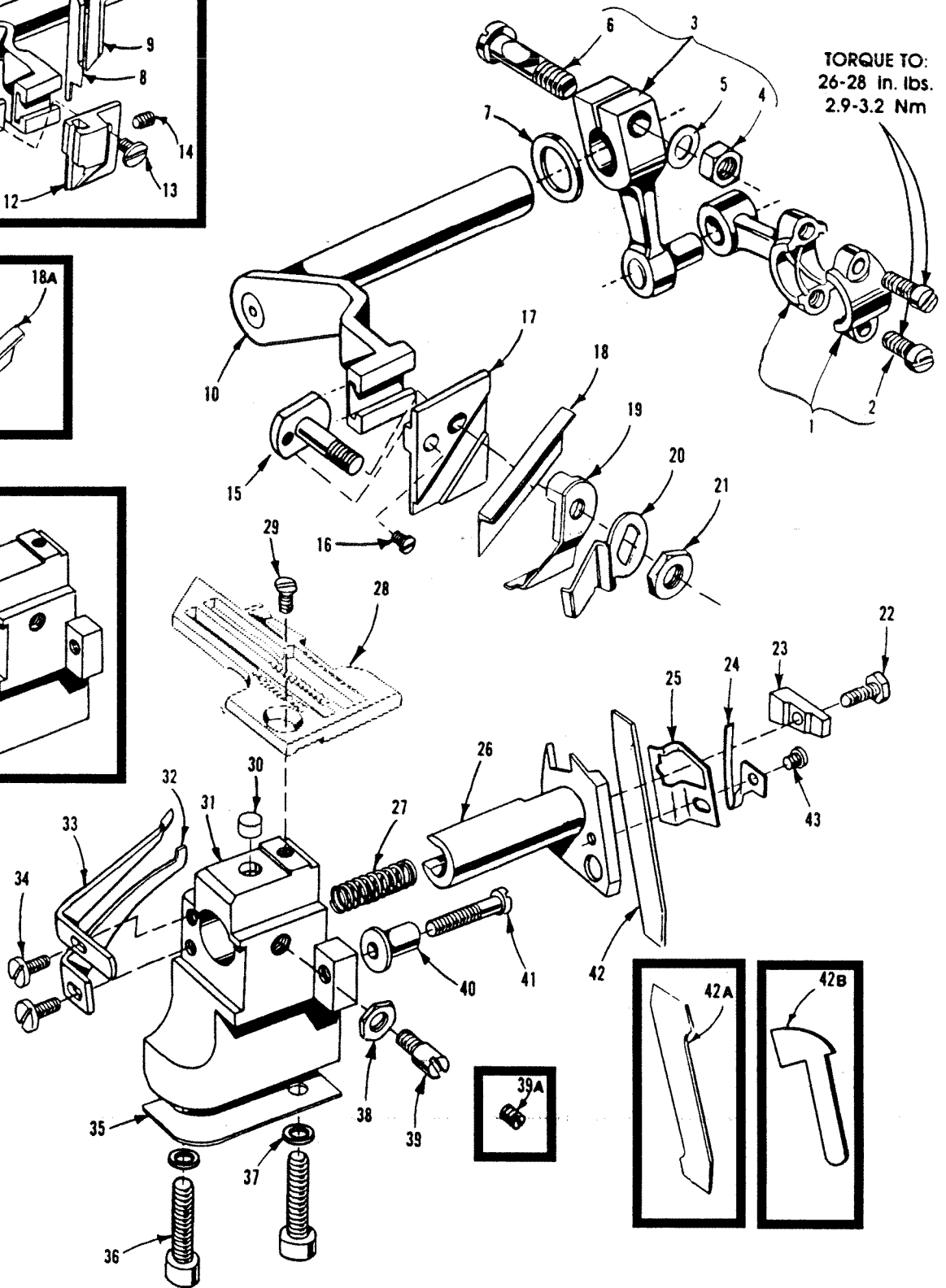
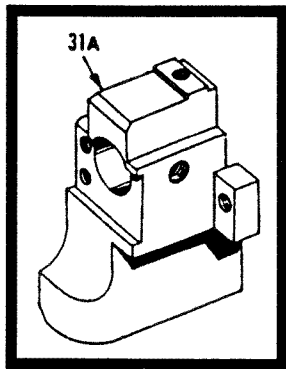
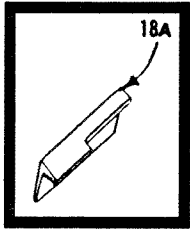
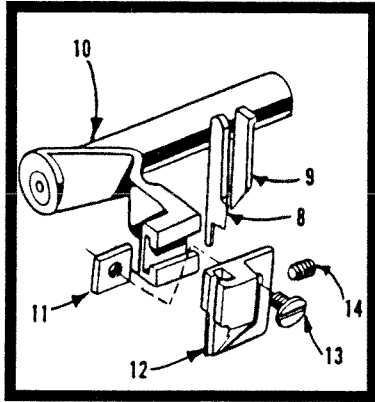

P054-92

UPPER & LOWER KNIFE PARTS

Ref. No.	Part No.	Description	Amt. Req.
1.	39573AE	Upper Knife Driving Connecting Rod	1
2.	22729AB	Screw	2
3.	39573E	Upper Knife Driving Lever	1
4.	55235E	Nut	1
5.	6042A	Washer	1
6.	55235D	Locking Stud	1
7.	39573A	Washer, for upper knife driving arm	1
8.	39270E	Upper Knife, for Style 39500 SF	1
9.	39571E	Upper Knife Clamp Bar, for Style 39500 SF	1
10.	39573H	Upper Knife Driving Arm	1
11.	39571A	Upper Knife Clamp Nut, for Style 39500 SF	1
12.	39572B	Upper Knife Holder Block, for Style 39500 SF	1
13.	22829	Screw, for upper knife holder block, Style 39500 SF	1
14.	22650CB-4	Set Screw, for upper knife, Style 39500 SF	1
15.	39571D	Upper Knife Clamp Stud, for all Styles except 39500 RR, SF	1
-	39571C	Upper Knife Clamp Stud, for Style 39500 RR	1
16.	22738	Screw, for 39571C and 39571D clamp stud	1
17.	39572	Upper Knife Holder Block, for all Styles except 39500 RR, SF	1
-	39572A	Upper Knife Holder Block, for Style 39500 RR	1
18.	39570	Upper Knife, for all Styles except 39500 RA, SF	1
18A.	39570K	Upper Knife, for Style 39500 RA	1
19.	39571F	Upper Knife Clamp, for all Styles except 39500 SF	1
20.	39571B	Upper Knife Chain Guard, for all Styles except 39500 SF	1
21.	14077	Nut, for 39571C and 39571D clamp stud	1
22.	22588J	Screw, for lower knife clamp	1
23.	39550AD	Lower Knife Clamp	1
24.	39550AE	Lower Knife Clamp Spring	1
25.	39550AC	Lower Knife Guide Plate	1
26.	39550AF	Lower Knife Holder	1
27.	39550E	Lower Knife Holder Spring	1
28.	-----	Throat Plate, see pages 27, 29, 31	1
29.	22524	Screw, for throat plate	1
30.	39880N	Rubber Bumper, for 39580A	1
31.	39580A	Throat Plate and Lower Knife Support Bracket, for all Styles except 39500 RA, RR, SF	1
31A.	39580AD	Throat Plate and Lower Support Bracket, for Styles 39500 RA, RR, SF	1
32.	39525R	Front Needle Guard, for all Styles except 39500 SF	1
-	39525L	Front Needle Guard, for Style 39500 SF	1
33.	GA39525N	Rear Needle Guard, for Styles 39500 QA, QB, QP, CQA, CQB	1
-	39525A	Rear Needle Guard, for Styles 39500 RA, RF, RR, RS, SE, SF, TE, CRF	1
-	39525P	Rear Needle Guard, for Styles 39500 SQB, SRF, CSRF	1
34.	22585A	Screw, for needle guards	2
35.	39580E	Shim, for Style 39500 SE 1/8 only	1
36.	22653B-12	Screw, for 39580A and 39580AD	2
37.	39580F	Washer, for 22653B-12	2
38.	14077	Nut, for 22892B	1
39.	22892B	Locking Screw, for lower knife holder, for all Styles except 39500 SF	1
39A.	88B	Locking Screw, for lower knife holder, for Style 39500 SF	1
40.	39550C	Lower Knife Holder Locking Stud	1
41.	22729B	Screw, for lower knife holder locking stud	1
42.	39549	Lower Knife, for all Styles except 39500 RA, SF	1
42A.	39549J	Lower Knife, for Styles 39500 RA, SF	1
42B.	39503H	Front Fabric Guide, for Style 39500 RR	1
43.	605A	Screw, for clamp spring	1

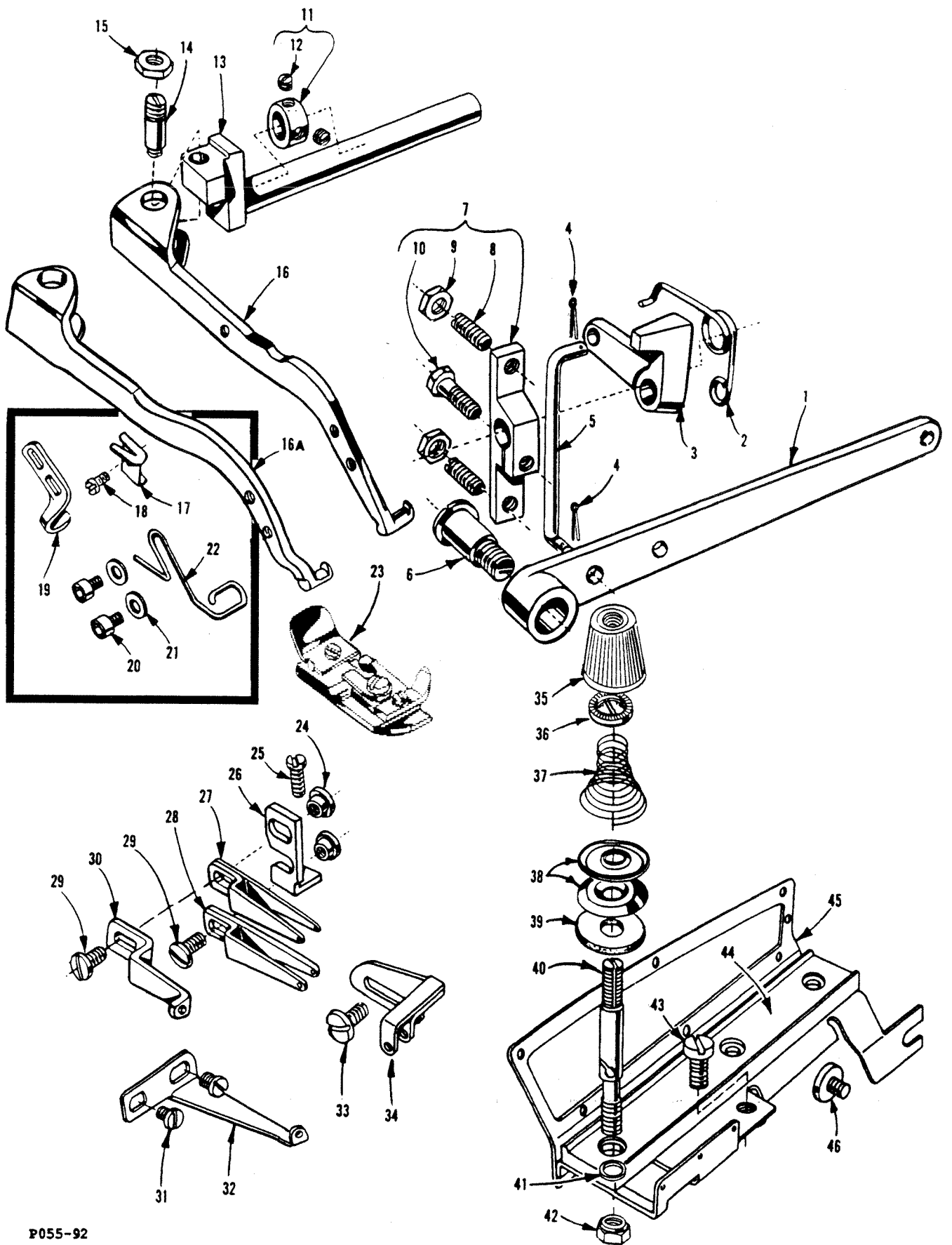

P055-92

FOOT LIFTER, CHAIN CUTTING KNIFE & MISCELLANEOUS EYELETS

Ref. No.	Part No.	Description	Amt. Req.
1.	39855	Foot Lifter Lever	1
2.	39555B	Foot Lifter Lever Spring	1
3.	39555D	Foot Lifter Intermediate Lever	1
4.	660-142	Cotter Pin, for foot lifter lever connecting link	2
5.	39555F	Foot Lifter Lever Connecting Link	1
6.	22566B	Screw, for foot lifter lever	1
7.	39555C	Foot Lifter Lever Arm	1
8.	22597E	Set Screw	2
9.	12538	Lock Nut	2
10.	627	Screw	1
11.	12865	Foot Lifter Lever Shaft Thrust Collar	1
12.	88	Screw	2
13.	39555AA	Foot Lifter Lever Shaft	1
14.	22791H	Screw Pin, for presser arm	1
15.	258A	Nut, for presser arm screw pin	1
16.	39556F	Presser Arm, for all Styles except 39500 SE	1
16A.	39556J	Presser Arm, for Style 39500 SE	1
17.	39556K	Chain Cutting Knife, for Style 39500 RR	1
18.	22704	Screw, for chain cutting knife	1
19.	39556H	Presser Foot Hold Down Plate, for Style 39500 RR	1
20.	99359	Screw, for finger guard, all Styles except 39500 RR, RS	2
-	99360	Screw, for finger guard, on Styles 39500 RR, RS	2
21.	95956	Washer, for finger guard screw, all Styles	2
22.	99682L	Finger Guard	1
23.	-----	Presser Foot, see pages 27, 29, 31	1
24.	43139A	Nut, for looper thread eyelet screws	2
25.	22569B	Screw, for looper thread eyelet mounting bracket	1
26.	39568D	Looper Thread Eyelet Mounting Bracket	1
27.	39568L	Upper Looper Thread Eyelet, for all Styles except 39500 RA, SF	1
-	39568T	Upper Looper Thread Eyelet, for Styles 39500 RA, SF	1
28.	39568B	Lower Looper Thread Eyelet, for all Styles except 39500 RA, SF	1
-	39568S	Lower Looper Thread Eyelet, for Styles 39500 RA, SF	1
29.	93A	Screw, for lower, upper and auxiliary looper thread eyelets	2
30.	39568E	Auxiliary Looper Thread Eyelet, for all Styles except 39500 RA, SF	1
-	39568U	Auxiliary Looper Thread Eyelet, for Styles 39500 RA, SF	1
31.	73X	Screw, for 39568W	2
32.	39568W	CQB, CRF, CSRF	1
33.	22569D	Screw, for needle thread eyelet	1
34.	39563H	Needle Thread Eyelet, for all Styles except 39500 RA, SF	1
-	39563U	Needle Thread Eyelet, for Styles 39500 RA, SF	1

35. thru 46. See following page

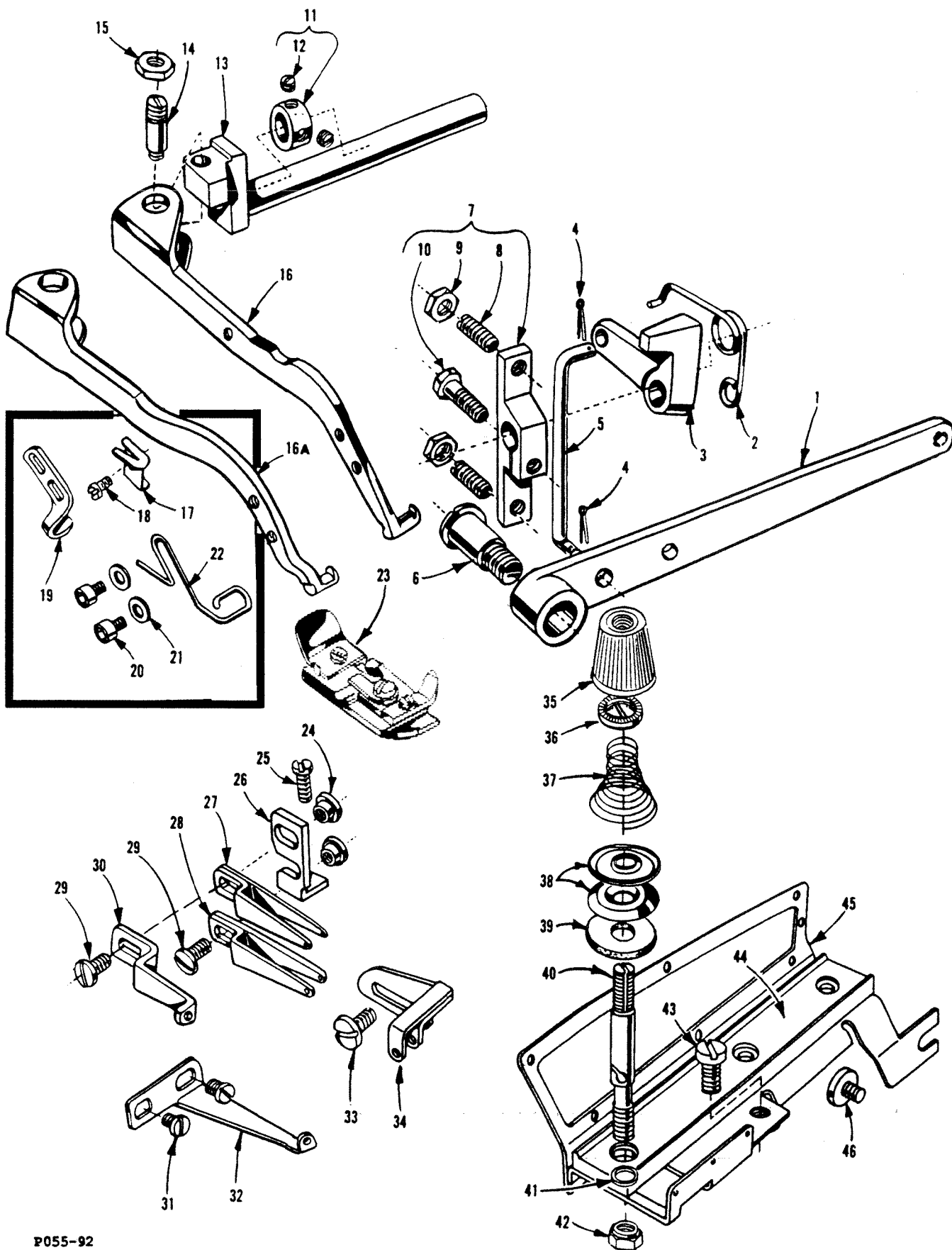

P055-92

THREAD TENSION PARTS

Ref. No.	Part No.	Description	Amt. Req.
1. thru 34. See preceding page			
35.	39592Z	Tension Nut	3
36.	39592AK	Tension Ferrule	3
37.	-----	Thread Tension Springs, (refer to Chart C)	-
38.	39592AD	Thread Tension Disc	6
39.	39592AF	Tension Disc Felt	3
40.	39592AL	Tension Post	3
41.	8372A	Washer	3
42.	39592AH	Locating Nut, for tension post	3
43.	22806A	Screw, for tension mounting bracket	1
44.	39592AM	Tension Post Bar	1
45.	39592AG-3	Tension Post Mounting Bracket	1
46.	22847B	Screw, for tension post mounting bracket	1

Machine Style	Upper Looper Spring	Needle Spring	Lower Looper Spring	Stitch Type
39500 QA, QB, QP, RF, SE, TE, CQA, CQB, CRF, SQB, SRF, CSRF	39592 AR-5	39592 AR-8	39592 AR-5	504
39500 RA	39592 AR-4	39592 AR-8	39592 AR-4	504
39500 RR	39592 AR-2	39592 AR-1 39592 AR-2	39592 AR-8 39592 AR-8	505 503
39500 RS	39592 AR-4	39592 AR-4	39592 AR-4	504
39500 SF	39592 AR-4	39592 AR-8	39592 AR-4	504

Chart C

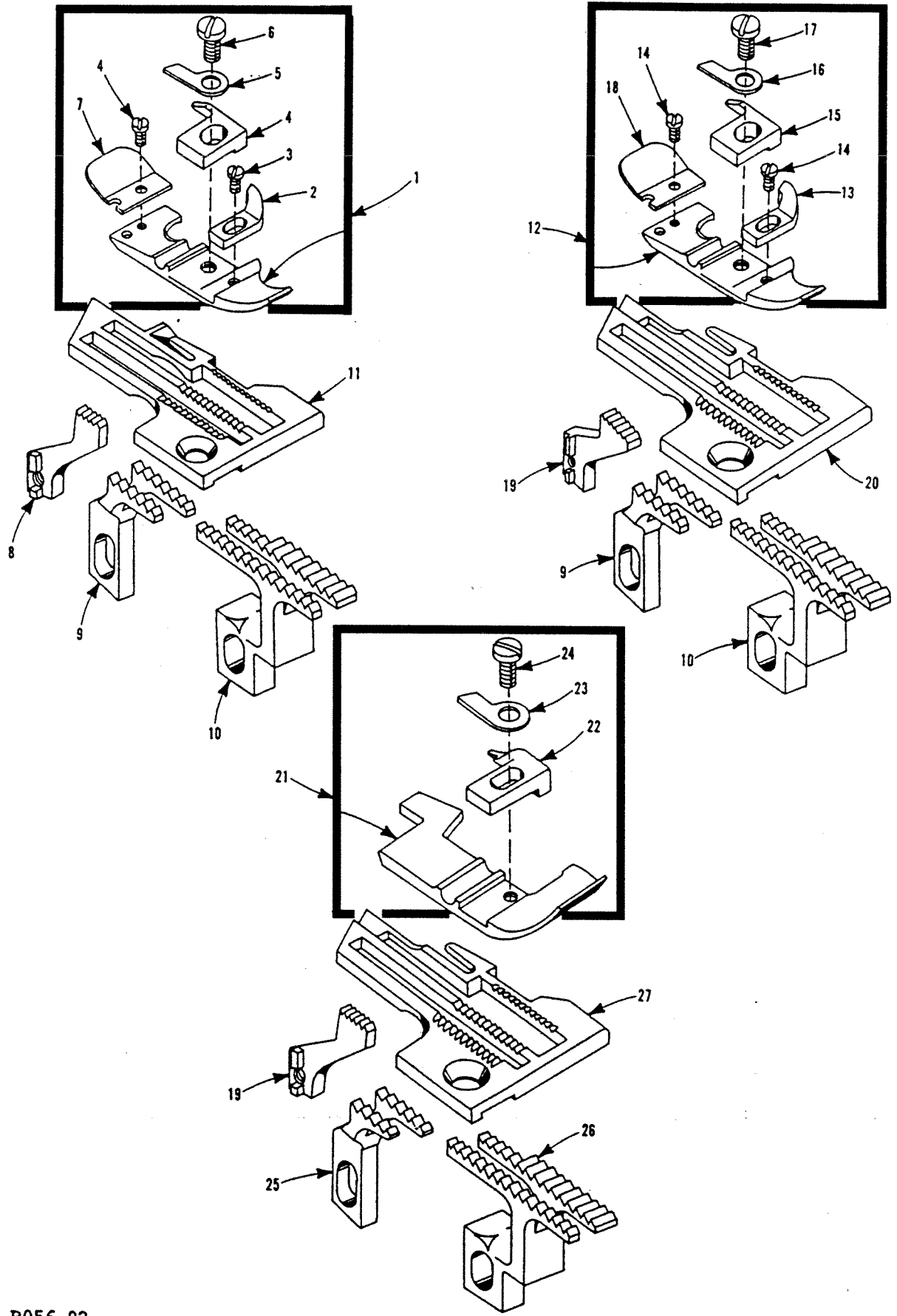

P056-92

FEED DOGS, THROAT PLATE & PRESSER FEET

Ref. No.	Part No.	Description	Amt. Req.
1.	39520B	Presser Foot, for Styles 39500 QA, CQA	1
2.	39530P	Chip Guard	1
3.	22738B	Screw	2
4.	39597A	Stitch Tongue, marked "DS"	1
5.	39530	Spring	1
6.	22768B	Screw	1
7.	39530C	Chain Shield	1
8.	39505C	Chaining Feed Dog, marked "C", 20 t.p.i., for Styles 39500 QA, RS, CQA	1
9.	39505B	Main Feed Dog, marked "B", 16 t.p.i., for Styles 39500 QA, QB, RF, CQA, CQB, CRF, SQB, SRF, CSRF	1
10.	39526B	Differential Feed Dog, 16 t.p.i., for Styles 39500 QA, QB, RF, CQA, CQB, CRF, SQB, SRF, CSRF	1
11.	C39524C 3/32	Throat Plate, marked "FC", for 3/32" (2.38mm) wide seam on Style 39500 QA	1
-	C39524C 1/8	Throat Plate, marked "FW", for 1/8" (3.17mm) wide seam on Styles 39500 QA, CQA	1
12.	39520A	Presser Foot, for Styles 39500 QB, RF, CQB, CRF, SQB, SRF, CSRF	1
13.	39530P	Chip Guard	1
14.	22738B	Screw	2
15.	39597A	Stitch Tongue, marked "DS"	1
16.	39530	Spring	1
17.	22768B	Screw	1
18.	39530C	Chain Shield	1
19.	39505E	Chaining Feed Dog, 20 t.p.i., for all Styles except 39500 QA, RS, TE, CQA	1
20.	C39524B 3/32	Throat Plate, marked "FU" for 3/32" (2.38mm) wide seam on Styles 39500 QB, RF, SQB, SRF	1
-	C39524B 1/8	Throat Plate, marked "FB" for 1/8" (3.17mm) wide seam on Styles 39500 QB, RF, CQB, CRF, SQB, SRF, CSRF	1
-	C39524B 5/32	Throat Plate, marked "FV", for 5/32" (3.97mm) wide seam on Styles 39500 QB, RF, CRF, SQB, SRF, CSRF	1
21.	39520P	Presser Foot, for Style 39500 QP	1
22.	39597P	Stitch Tongue, marked "EA"	1
23.	39530	Spring	1
24.	22768B	Screw	1
25.	39505P	Main Feed Dog, marked "J", 12 t.p.i., for Styles 39500 QP, RA, RR	1
26.	39526P	Differential Feed Dog, 12 t.p.i., for Style 39500 QP	1
27.	C39524P	Throat Plate, marked "FE", for 1/8" (3.17mm) wide seam on Style 39500 QP	1

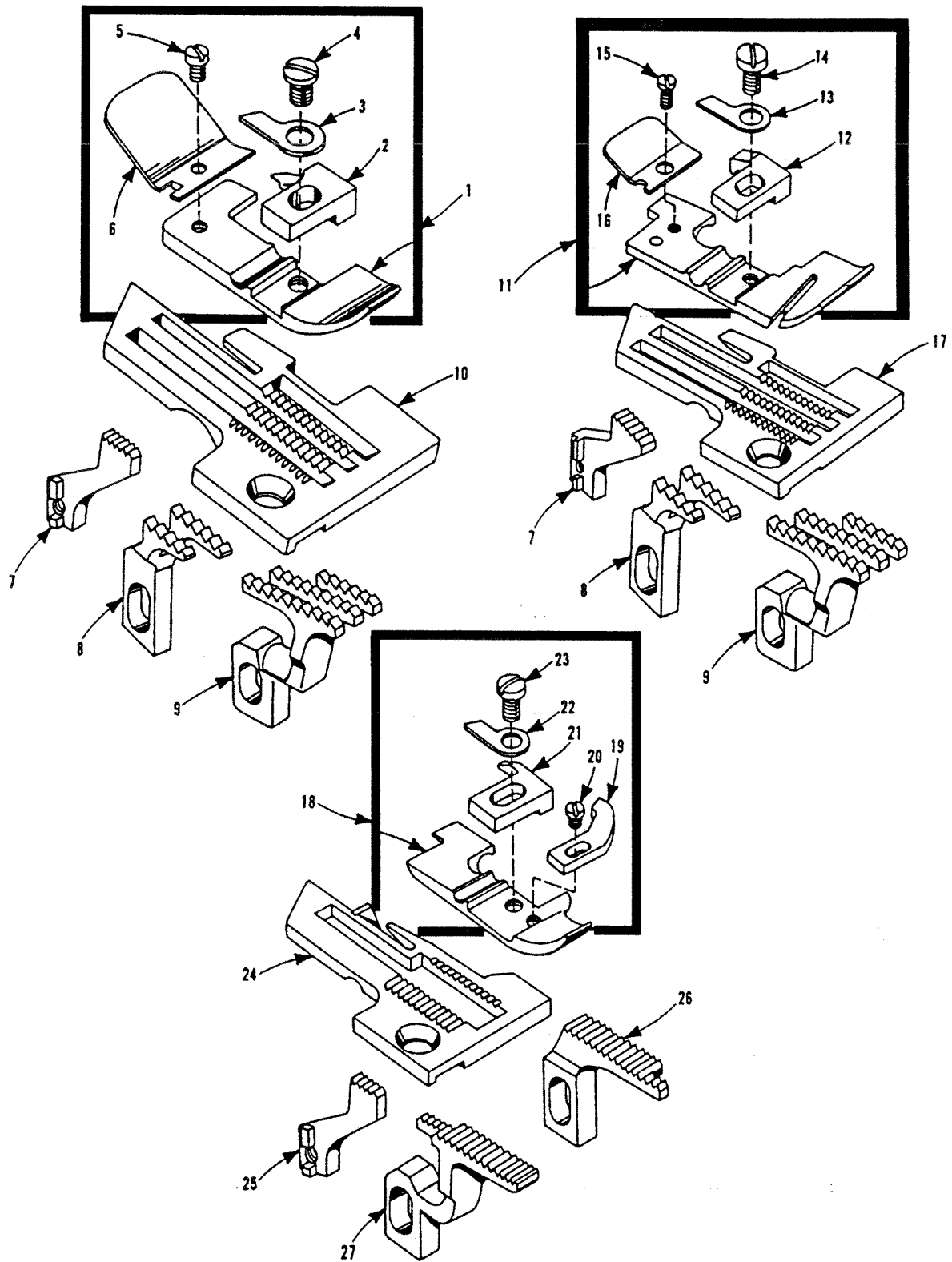

P057-92

FEED DOGS, THROAT PLATE & PRESSER FEET

Ref. No.	Part No.	Description	Amt. Req.
1.	39520AR	Presser Foot, for Style 39500 RR	1
2.	39597AR	Stitch Tongue, marked "EN"	1
3.	39530	Spring	1
4.	22768B	Screw	1
5.	22738B	Screw	1
6.	39530H	Chain Shield	1
7.	39505E	Chaining Feed Dog, 20 t.p.i., for all Styles except 39500 QA, RS, TE, CQA	1
8.	39505P	Main Feed Dog, marked "J", 12 t.p.i., for Styles 39500 QP, RA, RR	1
9.	39526AA	Differential Feed Dog, marked "AA", 12 t.p.i., for Styles 39500 RA, RR	1
10.	39524AR 1/4	Throat Plate, marked "BC 1/4", for 1/4" (6.35mm) wide seam on Style 39500 RR ...	1
11.	39520AA	Presser Foot, for Style 39500 RA	1
12.	39597AA	Stitch Tongue, marked "EG"	1
13.	39530	Spring	1
14.	22768B	Screw	1
15.	22738B	Screw	1
16.	39530C	Chain Shield	1
17.	39524AA	Throat Plate, marked "AT", for 5/32" (3.97mm) wide seam on Style 39500 RA	1
18.	39520AS	Presser Foot, for Style 39500 RS	1
19.	39530P	Chip Guard	1
20.	22738B	Screw	1
21.	39597AS	Stitch Tongue, marked "ES"	1
22.	39530	Spring	1
23.	22768B	Screw	1
24.	C39524AS	Throat Plate, marked "LE", for 3/32" (2.38mm) wide seam on Style 39500 RS	1
25.	39505C	Chaining Feed Dog, marked "C", 20 t.p.i., for Styles 39500 QA, RS, CQA	1
26.	39505AC	Main Feed Dog, marked "AM", 22 t.p.i., for Styles 39500 RS, SE	1
27.	39526AC	Differential Feed Dog, 22 t.p.i., for Styles 39500 RS, SE	1

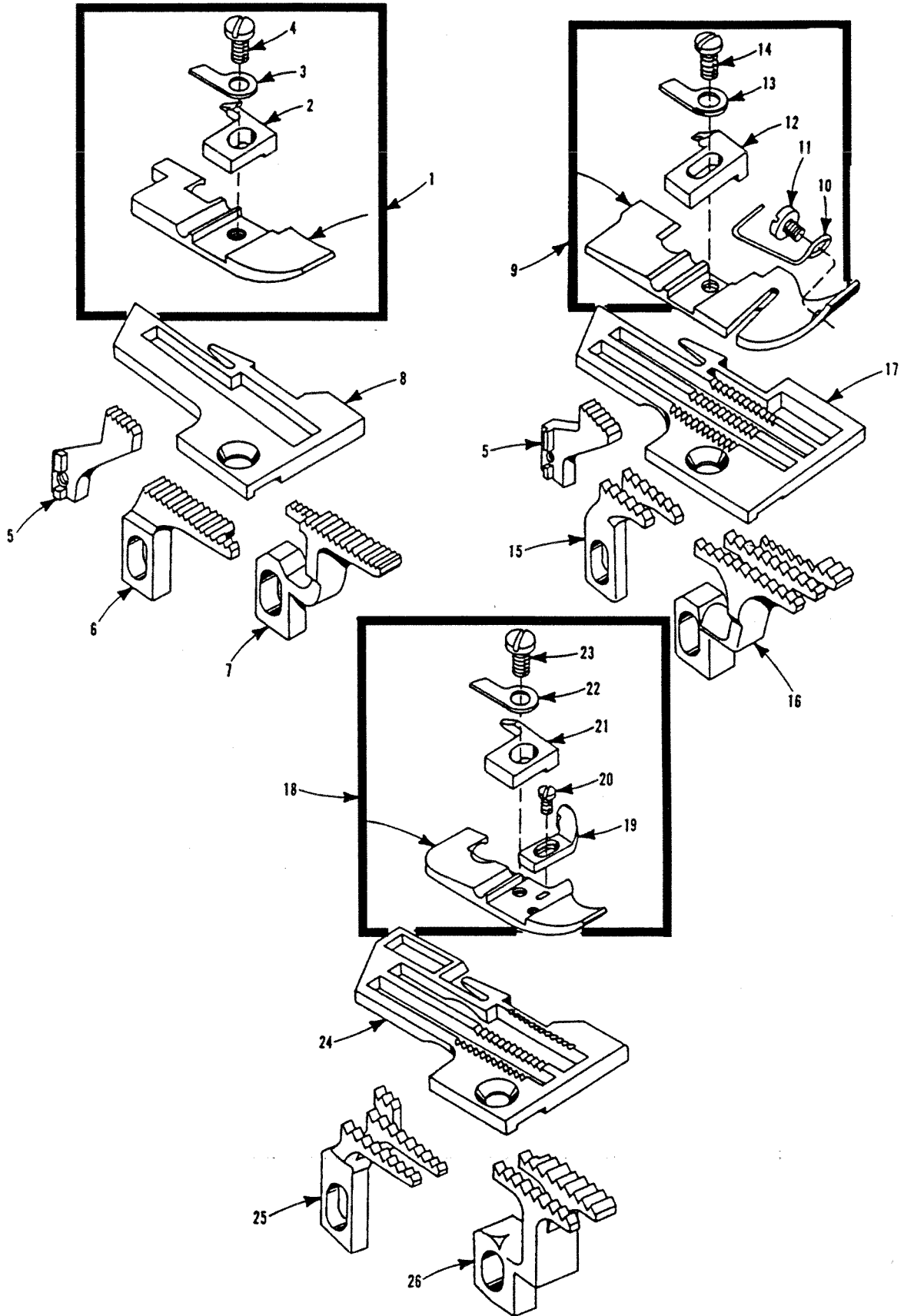

P058-92

FEED DOGS, THROAT PLATE & PRESSER FEET

Ref. No.	Part No.	Description	Amt. Req.
1.	39527AD	Presser Foot, for Style 39500 SE	1
2.	39597AB	Stitch Tongue, marked "EL"	1
3.	39530	Spring	1
4.	22768B	Screw	1
5.	39505E	Chaining Feed Dog, 20 t.p.i., for all Styles except 39500 QA, RS, TE, CQA	1
6.	39505AC	Main Feed Dog, marked "AM", 22 t.p.i., for Style 39500 RS, SE	1
7.	39526AC	Differential Feed Dog, 22 t.p.i., for Styles 39500 RS, SE	1
8.	C39528AD	Throat Plate, marked "LM", for 1/8" (3.17mm) wide seam on Style 39500 SE	1
	C39524AB 1/8	Throat Plate, marked "AX", for 1/8" (3.17mm) wide seam on Style 39500 SQB	1
9.	39520BF	Presser Foot, for Style 39500 SF	1
10.	39530BF	Tape Guide	1
11.	22798B	Screw	1
12.	39597P	Stitch Tongue, marked "EA"	1
13.	39530	Spring	1
14.	22768B	Screw	1
15.	39505BF	Main Feed Dog, marked "BY", 12 t.p.i., for Style 39500 SF	1
16.	39526BF	Differential Feed Dog, marked "BZ", 12 t.p.i., for Style 39500 SF	1
17.	C39524BF	Throat Plate, marked "LF", for 1/8" (3.17mm) wide seam on Style 39500 SF	1
18.	GA39520	Presser Foot, for Style 39500 TE	1
19.	G39530A	Chip Guard	1
20.	22738B	Screw	1
21.	39597A	Stitch Tongue, marked "DS"	1
22.	39530	Spring	1
23.	22738B	Screw	1
24.	GA39524C 1/8	Throat Plate, marked "HB", for 1/8" (3.17mm) wide seam on Style 39500 TE ...	1
25.	GA39505B	Main Feed Dog, marked "JL", 16 t.p.i., for Style 39500 TE	1
26.	G39526JV	Differential Feed Dog, 16 t.p.i., for Style 39500 TE	1

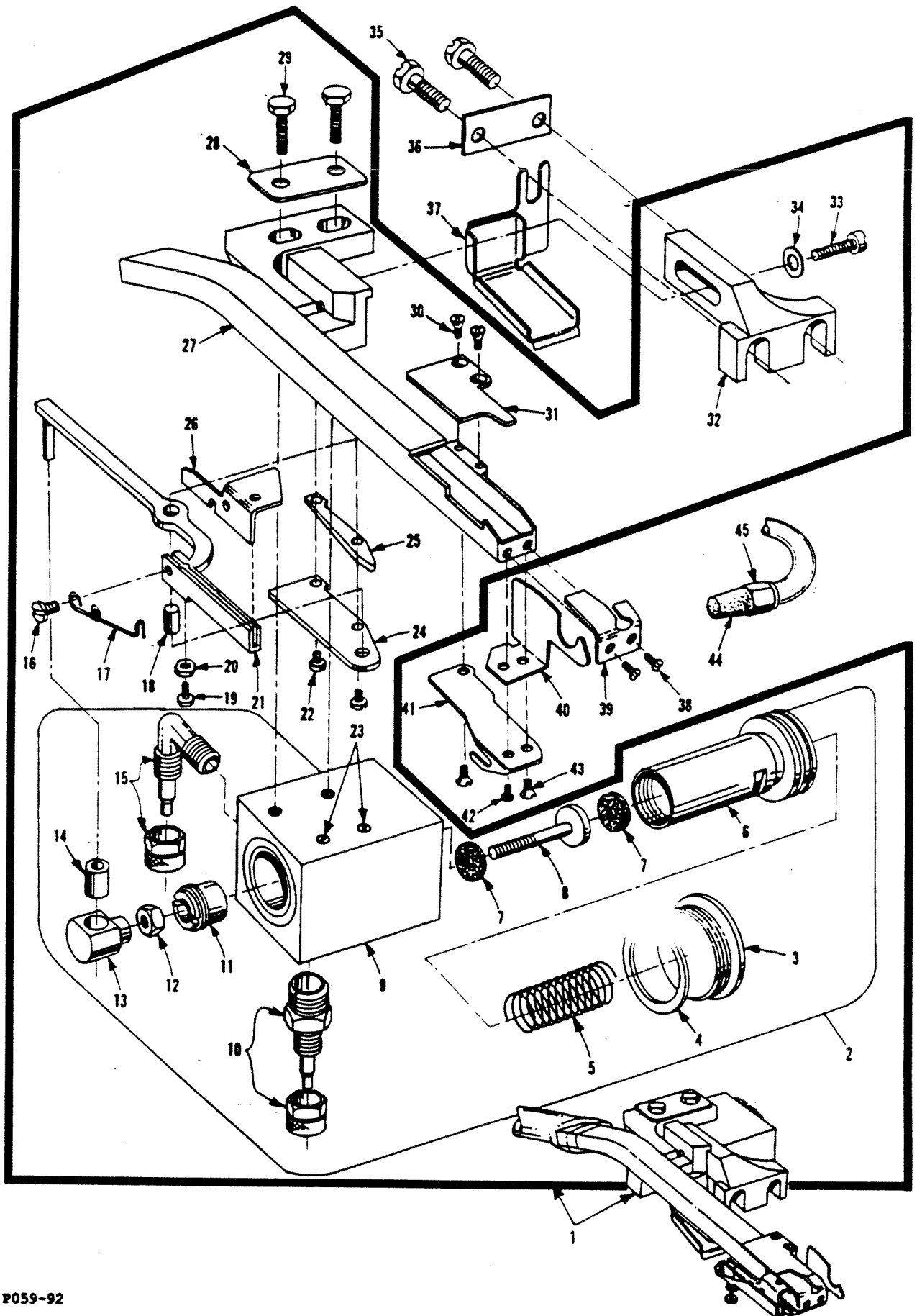

P059-92

POWER AIR-KLIPP® CHAIN CUTTER
(STYLES 39500 CQA, CQB, CRF, CSRF)

Ref. No.	Part No.	Description	Amt. Req.
1.	V29941AA	Power "AIR-KLIPP" Chain Cutter Assembly	1
2.	671H-1	Air-Motor Assembly	1
3.	671H-1D	Plug Screw	1
4.	671H-1F	Rubber Bumper	1
5.	660-753	Spring	1
6.	671H-1A	Vibrator	1
7.	671H-1H	Shock Washer	2
8.	39536DC	Stud	1
9.	671H-1B	Housing	1
10.	991-126F	Straight Fitting	1
11.	671H-1E	Plug Screw	1
12.	41071G	Nut	1
13.	39573AC	Drive Link	1
14.	671H-1G	Bushing	1
15.	999-141	Elbow Fitting	1
16.	22825	Screw	1
17.	99697DB	Torsion Spring	1
18.	39536DB	Pin	1
19.	22588K	Screw	1
20.	60078Z	Nut	1
21.	39573AB	Knife Driving Lever	1
22.	22738A	Screw	2
23.	12935A	Screw	2
24.	99663MD	Cover Plate	1
25.	99663MC	Spacer Plate	1
26.	99669KH	Lower Knife	1
27.	99676MC	Tube Assembly	1
28.	95910A	Plate Washer	1
29.	906	Screw	2
30.	22716	Screw	2
31.	99670LH	Upper Knife	1
32.	99663KA	Bracket	1
33.	22729D	Screw	1
34.	80265	Washer	1
35.	99373C	Mounting Screw	2
36.	95910B	Plate Washer	1
37.	39534RB	Oil Shield	1
38.	22716A	Screw, for Inlet	2
39.	99677H	Inlet, marked "GF", has a .130" (3.3mm) opening, for Style 39500 CQA	1
-	99677HA	Inlet, marked "GS", has a .169" (4.3mm) opening, for Styles 39500 CQA, CQB, CRF, CSRF	1
-	99677HD	Inlet, marked "GV", has a .205" (5.2mm) opening, for Styles 39500 CQB, CRF, CSRF	1
40.	99665	Fabric Guard	1
41.	99664C	Looper Thread Guide	1
42.	22716A	Screw, for inlet and fabric guard	1
43.	22716	Screw, for inlet and fabric guard	2
44.	999-140	Muffler	1
45.	999-126A	Connector	1

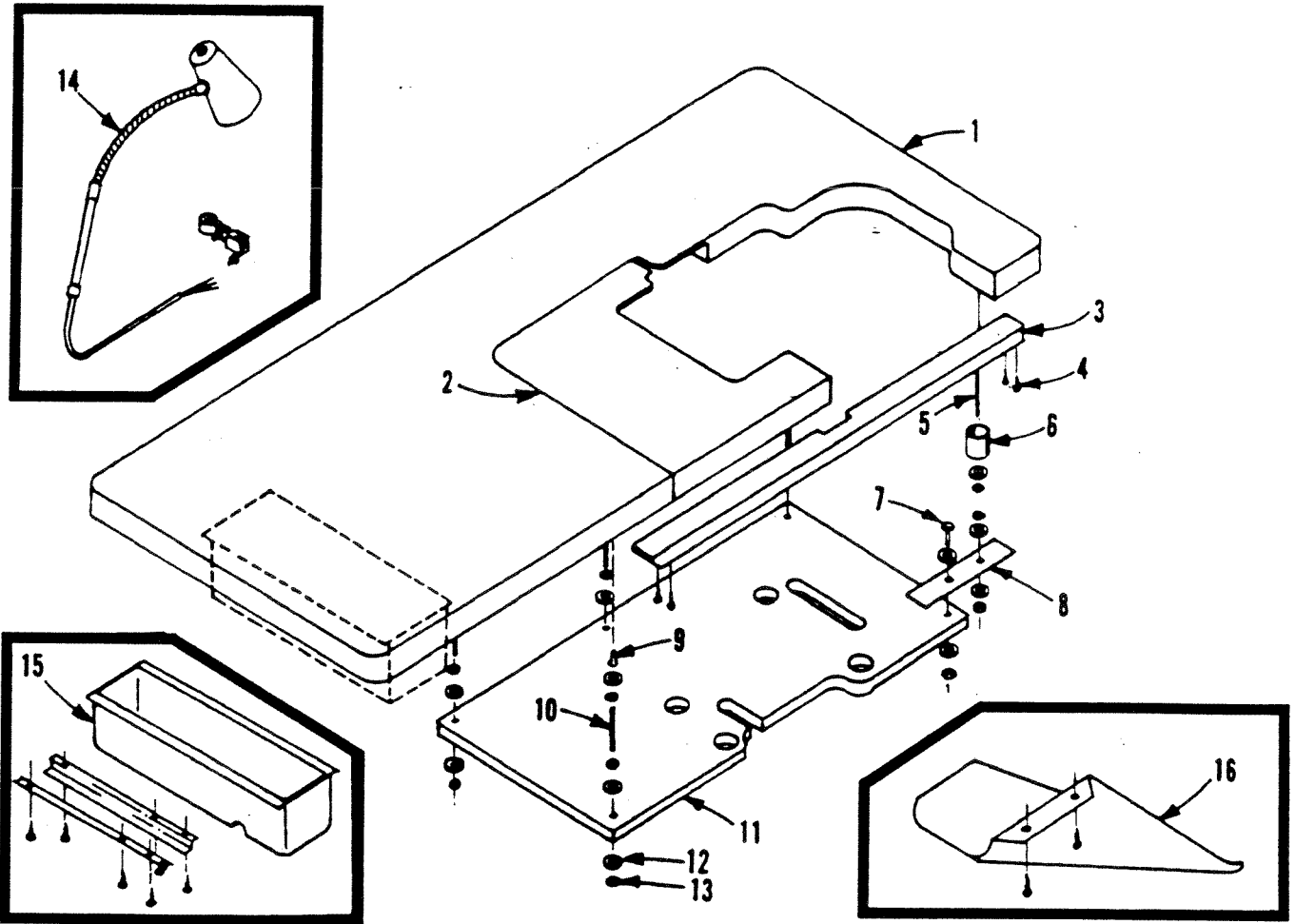

P060-92

FULLY-SUBMERGED TABLING

Ref. No.	Part No.	Description	Amt. Req.
1.	21371WL-48	Table Board	1
2.	30-96BLK	Insert	1
3.	30-97BLK	Table Board Brace	1
4.	SC470	Screw	4
5.	21371PY-32	Threaded Rod	1
6.	21371XW	Spacer	1
7.	22820A	Screw	1
8.	21371XY	Bracket	1
9.	660-276	Tap Lock Inserts	8
10.	21371PY-40	Threaded Rod	4
11.	21372AG	Underboard	1
12.	652 J-24	Washer	17
13.	651 B-24	Nut	16
14.	21233KH	Light	1
15.	21371Q	Drawer Assembly	1
16.	51278F	Chip Chute	1

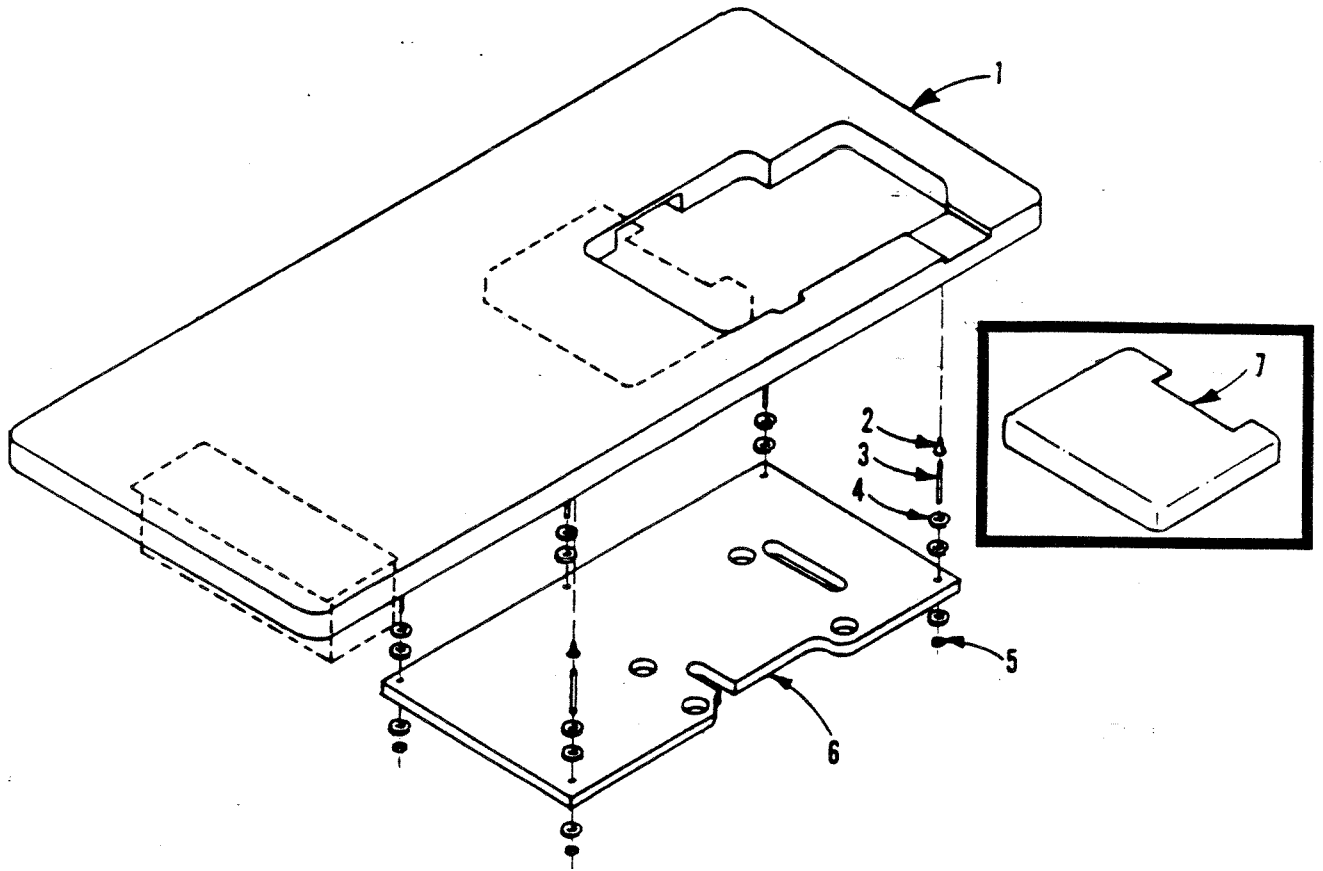

P061-92

SEMI-SUBMERGED TABLING

Ref. No.	Part No.	Description	Amt. Req.
1.	21371RL-48	Table Board	1
2.	660-276	Tap Lock Insert	5
3.	21371PY-28	Threaded Rod	5
4.	652J-24	Washer	15
5.	11698L	Nut	5
6.	21372AG	Underboard	1
7.	21377BP	Tray	1
-	21371Q	Drawer Assembly, (See page 34)	1
-	51278F	Chip Chute, (See page 34)	1
-	21233KH	Light, (See page 34)	1

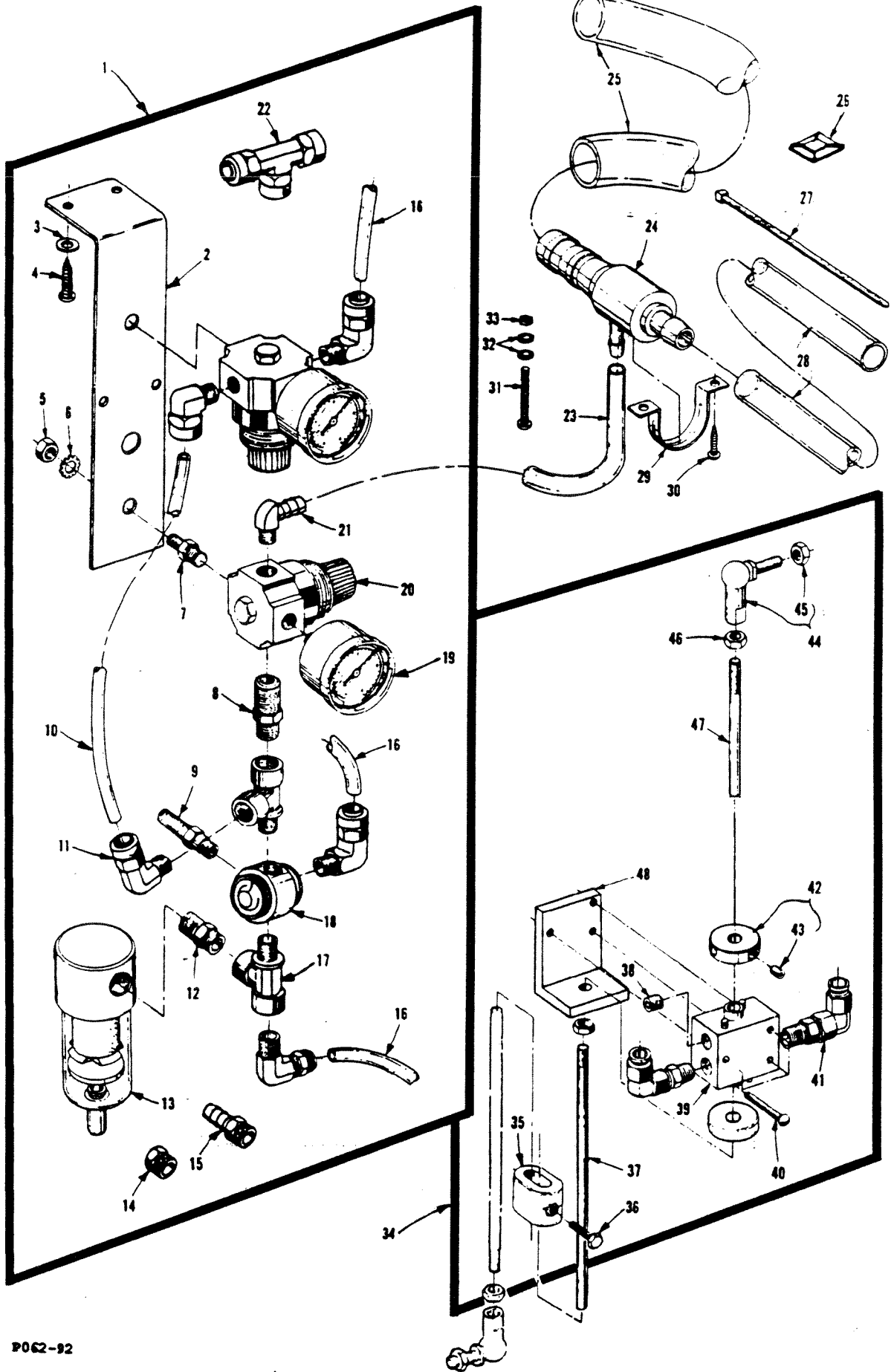

P062-92

PNEUMATIC CONTROL

Ref. No.	Part No.	Description	Amt. Req.
1.	29480UY	Pneumatic Control	1
2.	99638CC	Mounting Bracket	1
3.	39836AH	Washer	2
4.	RM2719-1	Wood Screw	2
5.	11635B	Nut	2
6.	652B-20	Washer	2
7.	671C-16	Mounting Stud	2
8.	RM3287-2	Hex Nipple	1
9.	660-403	Muffler	1
10.	660-392	Air Tube	1
11.	660-401	Elbow	5
12.	RM3320-1	Reducing Nipple	1
13.	671D-5	Air Line Filter	1
14.	671F-6	Reducing Bushing	1
15.	671F-1	Barb Fitting	1
16.	RM2997D	Tube, 1/4" (6.35mm) O.D. 13' (3.96 meters)	1
17.	RM2850D	Pipe Tee	2
18.	RM4098-1	Pilot Valve	1
19.	671D-15	Gauge	2
20.	671D-9	Regulator	2
21.	671F-2	Connector	1
22.	RM3384-1	Union Tee	1
23.	671B-3	Tube, venturi (air supply)	1
24.	671D-2	Venturi	1
25.	671B-11	Tube, discharge	1
26.	660-870	Cable Tie Mount	4
27.	RM2871B	Wire Tie	4
28.	671B-12	Tube, suction	1
29.	998-332	Holder, venturi	1
30.	RM2719-1	Screw, for wood table	2
31.	SC198	Screw, for metal table	2
32.	39836AH	Washer, for metal table	4
33.	NU13	Nut, for metal table	2
34.	29480ACD	Treadle Valve Assembly	1
35.	G28562A	Pitman Rod Connector	1
36.	95051	Screw	1
37.	99563A-130	Pitman Rod	1
38.	22571F	Plug Screw	1
39.	671-134	Valve Body	1
40.	SC191	Screw	3
41.	671F-69	Swivel Fitting	2
42.	C50036AS	Actuating Collar	2
43.	22894R	Screw	2
44.	999-146	Link	2
45.	95250	Nut	2
46.	95250	Hex Nut	3
47.	99563A-75	Pitman Rod	1
48.	671-135	Mounting Bracket	1

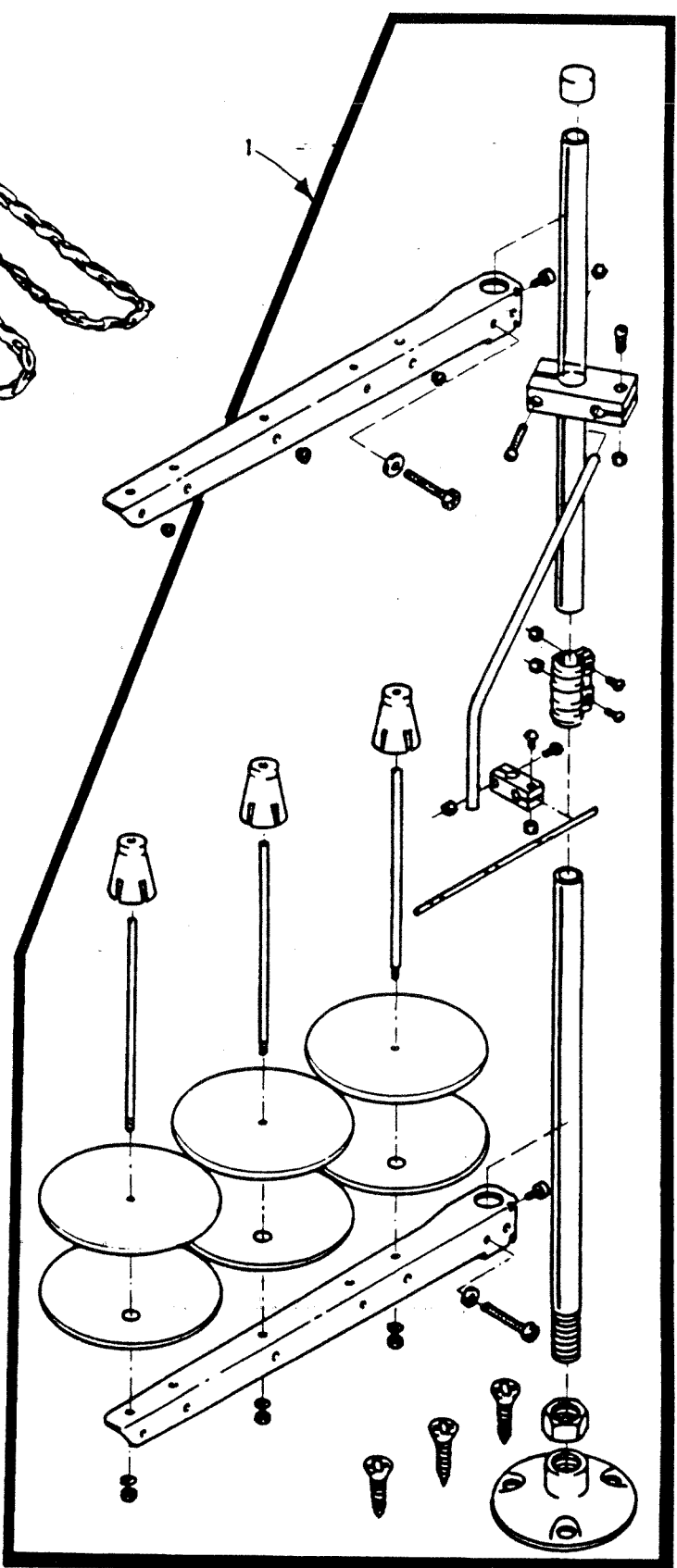
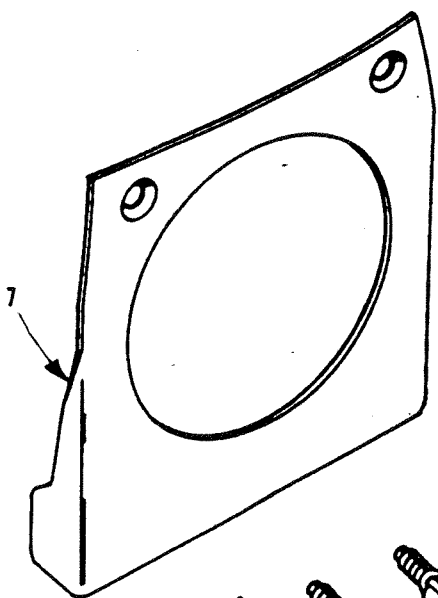
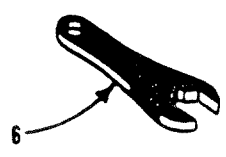
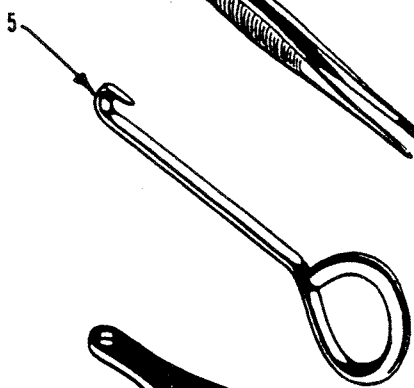
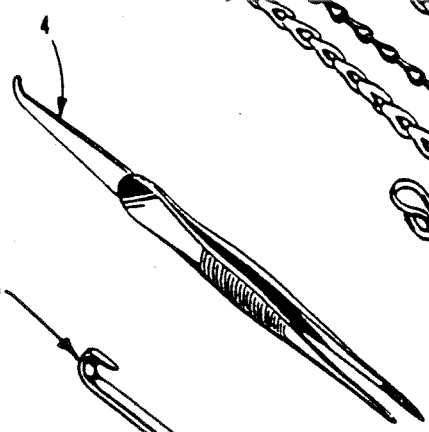
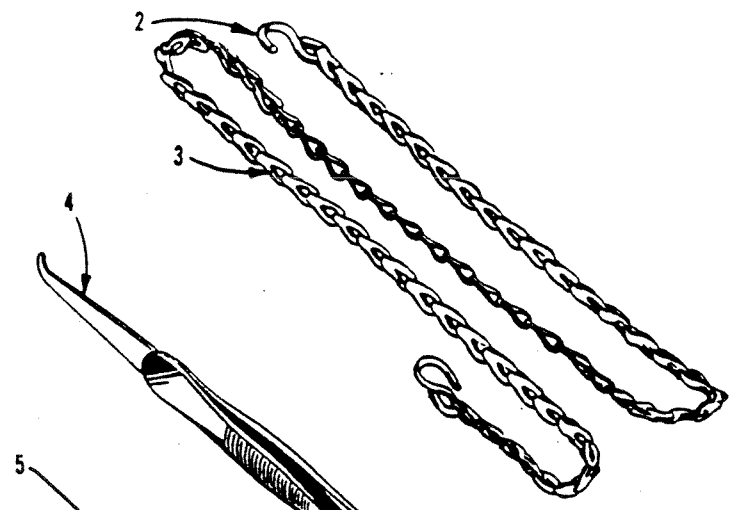

P063-92

THREAD STAND & MISCELLANEOUS ACCESSORIES

Ref. No.	Part No.	Description	Amt. Req.
1.	21101W3	Thread Stand	1
2.	660-264	"S" Hook, for treadle chain	2
3.	421 D-34	Treadle Chain, for presser foot lifter	1
4.	660-240	Tweezers	1
5.	21227DR	Cam Extractor	1
6.	116	Wrench, for 9/32" (7.142 mm) nuts	1
7.	21375BB	Belt Guard	1
8.	80	Screws, for belt guard	2
-	21388AU	Socket Wrench, for 3/8" (9.52 mm) nuts holding feed eccentrics (not shown)	1
-	28604R	Pint of Oil (not shown)	1
-	660-458	Dust Cover (not shown)	1
-	652-24	Washer (not shown)	8

NUMERICAL INDEX OF PARTS

102L 19	22716A 33	39520AR 29	39544J 19	39571B 21
1096 11	22729 AB 13	39520AS 29	39544S 19	39571C 21
116 39	22729AB 19, 21	39520B 27	39544U 19	39571D 21
11635B 37	22729B 21	39520BF 31	39544V 19	39571E 21
11698L 35	22729D 33	39520P 27	39544Z 13	39571F 21
12538 23	22738 21	39521J 13	39549 21	39572 21
12865 23	22738A 33	39524AA 29	39549J 21	39572A 21
12935A 33	22738B 27, 29, 31	39524AR 1/4 29	39550AC 21	39572B 21
138 9	22743 11	39525A 21	39550AD 21	39573A 21
14077 21	22747B 13	39525L 21	39550AE 21	39573AA 13
14077A 17	22760H 11	39525P 21	39550AF 21	39573AB 33
21101W3 39	22768B 27, 29, 31	39525R 21	39550C 21	39573AC 33
21227BF 39	22768C 13	39526AA 29	39550E 21	39573AE 21
21227DR 39	22782A 17	39526AC 29, 31	39551H 17	39573E 21
21233KH 34, 35	22791H 23	39526B 27	39551J 17	39573H 21
21371PY-28 35	22797A 15	39526BF 31	39552AD 17	39573K 13
21371PY-32 34	22798B 31	39526P 27	39552AG 17	39578 P 15
21371PY-40 34	22804 11	39527AD 31	39552AJ 17	39578 R 15
21371Q 34, 35	22806A 25	39530 27, 29, 31	39552P 13	39578AH 11
21371RL-48 35	22820A 34	39530BF 31	39552R 17	39578F 9
21371WL-48 34	22825 33	39530C 27, 29	39552U 13	39580A 21
21371XW 34	22829 21	39530H 27	39552Z 17	39580AD 21
21371XY 34	22847B 25	39530P 27, 29	39555AA 23	39580E 21
21372AG 34, 35	22875M 19	39532A 9	39555B 23	39580F 21
21375BB 39	22892B 21	39532E 9	39555C 23	39582AD 9
21377BP 35	22894AE 11, 19	39534 15	39555D 23	39582AF 9
21388AU 39	22894C 19	39534AF 15	39555F 23	39582AG 9
22503F 19	22894D 13	39534C 15	39555P 13	39582BH 11
22513C 13, 17, 19	22894R 37	39534G 15	39555R 13	39582BL 11
22513D 17	22894Y 19	39534R 9	39556F 23	39582BM 11
22524 21	258A 23	39534RB 9, 33	39556H 23	39582BW 11
22528 15	28604R 39	39535C 15	39556J 23	39582BZ 9
22541 9	29126DF 19	39535D 15	39556K 23	39582F 11
22541B 11, 15	29126EC 19	39535J 15	39557 9	39582FE 11
22562A 9	29477JM 13	39535W 15	39557A 9	39582FH 11
22564G 19	29477KE 13	39536AE 15	39557B 9	39582GJ 11
22565 9, 19	29477MC 13	39536AF 15	39557C 9	39582GL 11
22565F 9, 13, 15	29477MX 11	39536B 15	39557E 9	39582V 9
22565H 19	29480ACD 37	39536C 15	39557F 9	39582W 9
22565S 9, 19	29480UY 37	39536DB 33	39560A 19	39590AB 13
22566B 23	30-96BLK 34	39536DC 33	39563F 9	39590D 13
22569 9, 11	30-97BLK 34	39536E 15	39563G 17	39590G 13
22569B 9, 13, 15, 23	39151 19	39536FN 13	39563H 23	39590H 13
22569D 9, 11, 23	39270E 21	39538 15	39563T 9	39590J 13
22569G 15	39501D 9	39541A 13	39563U 23	39590T 13
22569K 11	39501DB 9	39543 19	39568AC 17	39590Y 13
22571E 9	39501E 9	39543A 19	39568AM 17	39591A 13
22571F 37	39501K 9	39543AJ 19	39568AN 11	39591B 13
22585A 21	39503H 21	39543AT 19	39568AP 11	39591H 13
22586T 11	39505AC 29, 31	39543AU 19	39568B 23	39591K 13
22588J 21	39505B 27	39543AV 19	39568D 23	39591L 13
22588K 33	39505BF 31	39543E 19	39568E 15, 23	39592AD 25
22596H 13, 17	39505C 27, 29	39543N 19	39568J 11	39592AF 25
22597E 23	39505E 27, 29, 31	39543P 19	39568L 23	39592AG-3 25
22650CB-4 21	39505P 27, 29	39543W 19	39568S 23	39592AH 25
22650CD-4 13	39508A 19	39543X 19	39568T 23	39592AK 25
22653B-12 21	39508B 19	39543Y 17	39568U 23	39592AL 25
22653D-4 11	39508D 19	39544 19	39568W 23	39592AM 25
22657D-10 9	39508E 19	39544AA 19	39570 21	39592Z 25
22704 23	39520A 27	39544B 19	39570K 21	39593C 11
22716 33	39520AA 29	39544D 19	39571A 21	39593D 11

NUMERICAL INDEX OF PARTS

39593H	11	660-392	37	99373C	33
39593J	11	660-401	37	99563A-130	37
39593U	13	660-403	37	99563A-75	37
39593U-123	13	660-443	13	99638CC	37
39593U-1235	13	660-458	39	99663KA	33
39593U-124	13	660-753	33	99663MC	33
39593U-1245	13	660-764	13	99663MD	33
39593U-125	13	660-835	13	99664C	33
39593U-1255	13	660-870	37	99665	33
39593U-126	13	660-885	11	99669KH	33
39593U-1265	13	666-280	11	99670LH	33
39593U-127	13	666-94	13	99676MC	33
39593U-1275	13	667D-8	9	99677H	33
39593U-128	13	671-134	37	99677HA	33
39593U-1285	13	671-135	37	99677HD	33
39593U-129	13	671B-11	37	99682L	23
39594G	11	671B-12	37	99697DB	33
39594H	11	671B-3	37	998-332	37
39594N	13, 17, 19	671C-16	37	999-126A	33
39594R	9	671D-15	37	999-140	33
39595	11	671D-2	37	999-141	33
39597A	27, 31	671D-5	37	999-146	37
39597AA	29	671D-9	37	C39524AS	29
39597AB	31	671F-1	37	C39524B 1/8	27
39597AD	31	671F-2	37	C39524B 3/32	27
39597AR	29	671F-6	37	C39524B 5/32	27
39597AS	29	671F-69	37	C39524BF	31
39597P	27, 31	671H-1	33	C39524C 1/8	27
39599	11	671H-1A	33	C39524C 3/32	27
39835G	15	671H-1B	33	C39524P	27
39836AH	37	671H-1D	33	C39528AD	31
39855	23	671H-1E	33	C50036AS	37
39880N	21	671H-1F	33	C50043H-029	17
41071G	11, 33	671H-1G	33	G28562A	37
41358	11, 15	671H-1H	33	G39501D	9
421D-34	39	69H	11	G39501K	9
43139A	23	73X	23	G39508A	19
482C	19	77	19	G39526JV	31
51-103BLK	9	80	39	G39530A	31
51278F	34, 35	80265	33	G39578M	15
51295B	11	8372A	15, 25	G39578T	11
55235D	21	86X	11	G39578TB	11
55235E	21	87	15	G39578U	11
56393G	11	87B	15	GA39505B	31
56393V	11	87C	17	GA39520	31
60078Z	33	87U	15	GA39524C 1/8	31
6042A	21	88	23	GA39525N	21
605A	21	88B	17, 21	NU13	37
627	23	90	9	RI-37	11
643-480BLK	11	906	33	RM2719-1	37
651B-24	34	93A	15, 23	RM2850D	37
652-24	39	95051	37	RM2871B	37
652B-20	37	95250	37	RM2997D	37
652J-24	34, 35	95910A	33	RM3287-2	37
660-142	23	95910B	33	RM3320-1	37
660-206	19	95956	23	RM3384-1	37
660-207	17	97	19	RM4098-1	37
660-240	39	97 A	13	SC191	37
660-243	11	991-126F	33	SC198	37
660-264	39	99359	23	SC470	34
660-276	34, 35	99360	23	V29941AA	33

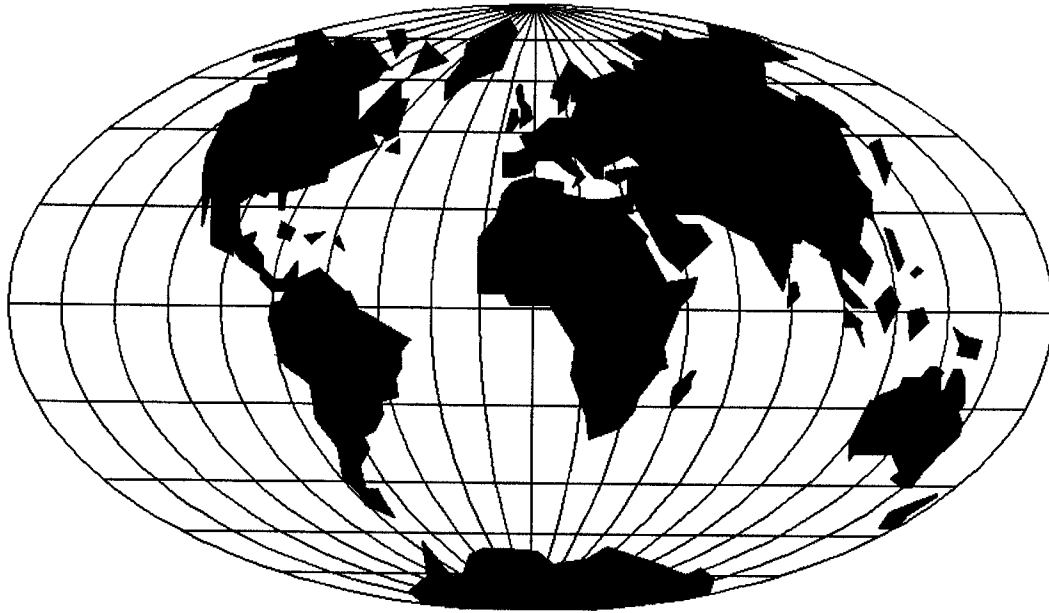

WORLDWIDE SALES AND SERVICE
WELTWEITER VERKAUF UND KUNDENDIENST

Union Special maintains sales and service facilities throughout the world. These offices will aid you in the selection of the right sewing equipment for your particular operation. Union Special representatives and service technicians are factory trained and are able to serve your needs promptly and efficiently. Whatever your location, there is a qualified representative to serve you.

Corporate
Office:

Union Special Corporation
One Union Special Plaza
Huntley, IL 60142
Phone: US: 800-344 9698
Phone: 847-669 4200
Fax: 847-669 4355
E-mail: bags@unionspecial.com
www.unionspecial.com

European Distribution Center:

Union Special GmbH
Raiffeisenstrasse 3
D-71696 Möglingen, Germany
Tel.: 49 (0)7141/247-0
Fax: 49 (0)7141/247-100
E-mail: sales@unionspecial.de
www.unionspecial.de

Union Special unterhält Verkaufs- und Kundendienst-Niederlassungen in der ganzen Welt. Diese helfen Ihnen in der Auswahl der richtigen Maschine für Ihren speziellen Bedarf. Union Special Vertreter und Kundendiensttechniker sind in unseren Werken ausgebildet worden, um Sie schnell und fachmännisch zu bedienen.

 **Union Special**[®]
Finest Quality